



Construction Standards

*Jeffersonville Wastewater
Department
City of Jeffersonville, Indiana*

March 2026

On order to provide consistency in the construction and installation of new sanitary sewer facilities or the repair and/or replacement of sewers facilities, the City of Jeffersonville Sanitary Sewer Board has Reviewed and Adopts these Standards which with go into effect this 19th day of March, 2026.

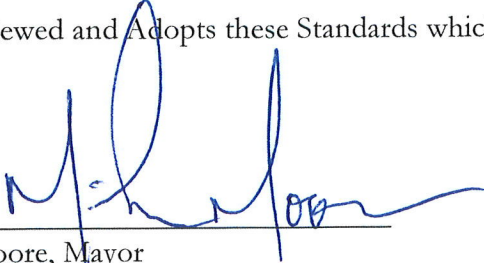

Mike Moore, Mayor
President of the Sanitary Sewer Board



Dale Orem, Board Member



Bill Saegesser, Board Member

ATTEST:



Cindy Seifert
Sanitary Sewer Board Secretary

Table of Contents

Section	Title	Page No.
<i>1.0</i>	<i>INTRODUCTION.....</i>	<i>1</i>
1.1	Forward.....	1
1.2	Contact Information.....	1
1.3	Referenced Documents.....	1
1.4	Definitions.....	1
1.5	Permit Applications.....	2
1.6	Expiration of Permit.....	3
1.7	Payment of Fees.....	3
<i>2.0</i>	<i>Sanitary Sewers.....</i>	<i>5</i>
2.1	General.....	5
2.2	Design.....	7
2.3	Materials.....	11
2.4	Execution.....	13
<i>3.0</i>	<i>SANITARY SEWER LIFT STATIONS/FORCE MAINS.....</i>	<i>21</i>
3.1	General.....	21
3.2	Design.....	22
3.3	Materials – Submersible Lift Station Structures and Equipment.....	24
3.4	Materials – Force Mains.....	32
3.5	Execution.....	35
<i>4.0</i>	<i>BORE AND JACK.....</i>	<i>41</i>
<i>5.0</i>	<i>LOW PRESSURE SEWER SYSTEMS (LPSS).....</i>	<i>43</i>
5.1	Purpose.....	43
5.2	Overview.....	43
5.3	General Location Criteria.....	44
5.4	Horizontal Alignment Criteria.....	45
5.5	Vertical Alignment Criteria.....	46
5.6	LPSS Hydraulic Design Criteria.....	47
5.7	Hydraulic Computations.....	48
5.8	LPSS Pipe.....	48
5.9	Grinder Pump Station.....	51
5.10	Property Service Connections.....	60
5.11	LPSS Main Line Air Valves.....	61
5.12	Flushing Assembly and Vault.....	61
5.13	Horizontal Directional Drilling.....	62

6.0	<i>FATS, OIL AND GREASE REQUIREMENTS.....</i>	67
6.1	<i>General Requirements.....</i>	67
6.2	<i>Design, Sizing and Installation Requirements.....</i>	69
6.3	<i>General Maintenance</i>	70
6.4	<i>Sampling and Testing.....</i>	72
<i>APPENDIX A</i>	<i>Wastewater Department Capacity Fee Schedule.....</i>	74
<i>APPENDIX B</i>	<i>Air Pressure Test Data Sheet.....</i>	76
<i>APPENDIX C</i>	<i>Mandrel Test Report.....</i>	77
<i>APPENDIX D</i>	<i>Sewer Manhole Test Report.....</i>	78
<i>APPENDIX E</i>	<i>Department Requirements for Sewer Locates for Directional Drilling...</i>	80
<i>APPENDIX F</i>	<i>Commercial Connections to Jeffersonville Sewer Main.....</i>	81
<i>STANDARD</i>	<i>Standard Sanitary Sewer Drawings & Details- Cover Sheet.....</i>	82
<i>DETAILS</i>	<i>Pipe Bedding and Crossing Details.....</i>	83
	<i>Sanitary Sewer Structure Details.....</i>	84
	<i>Sanitary Lateral Connection & Miscellaneous Details.....</i>	85
	<i>Force Main Details.....</i>	86
	<i>Electrical Control Cabinet & Enclosure Details.....</i>	87
	<i>Pump (Lift) Station Details.....</i>	88
	<i>Low Pressure Sewer System Details.....</i>	89

SECTION 1. INTRODUCTION

1.1 Forward

- A) The purpose of these standards is intended to provide a uniform standard for all sanitary sewer construction projects located within the jurisdiction of the City of Jeffersonville, Indiana. These specifications are intended to complement the City of Jeffersonville Standard Construction Details. Specifications for all storm sewer construction located within the jurisdiction of the City of Jeffersonville are provided in the City of Jeffersonville Stormwater Technical Standards Manual and the Standard Construction Details, current versions.
- B) At the time of project plan approval, a project is required to comply with the latest revision of standard specifications and details. Developers are encouraged to provide the latest revisions to their contractors before construction. Developer's engineers should not include other specifications and details unless required by the uniqueness of the project.
- C) These specifications and details are expected to be updated as new standards are developed and as errors and discrepancies are discovered. Please forward any comments to the City Engineer for consideration in future updates.

1.2 Contact Information

City Engineer	(812) 285-6476
Wastewater Department Director	(812) 285-6451

1.3 Referenced Documents

City of Jeffersonville Standard Construction Details
City of Jeffersonville Unified Development Ordinance

Indiana Department of Transportation (INDOT) Standard Specifications, Supplemental, and Standard Drawings

Indiana Department of Transportation (INDOT) Design Manual

AASHTO – A Policy on Geometric Design of Highways and Streets (AASHTO Manual or Green Book)

Manual on Uniform Traffic Control Devices (MUTCD) ASTM / AASHTO standard specifications

Recommended Standards for Wastewater Facilities – A Report of the Wastewater Committee of the Great Lakes – Upper Mississippi River (Ten States Standards)

Other generally acceptable design standards, policies, and guides

1.4 Definitions

- A) For the purpose of these Construction Standards and Details, the following definitions shall apply:
 - 1) **Applicant** – Shall mean the person, company, or individual who applies for a permit to construct sanitary sewers in the City of Jeffersonville or its service area. It shall also be known as the permittee.

- 2) **City** – City shall mean the City of Jeffersonville, Indiana, the municipality which has jurisdiction over its corporate limits
- 3) **City Engineer** – The Director of the City of Jeffersonville Engineering Department, acting directly or through the duly authorized representatives.
- 4) **Contractor** – Any individual, partnership, firm, corporation, or combination of same approved by the City of Jeffersonville to construct, install, maintain, repair and remove public or private street, sanitary sewer, or storm sewer facilities within the City of Jeffersonville’s service area. This definition is intended to include all employees, sub-contractors and/or agents acting for or on behalf of the Contractor.
- 5) **Department** – Shall mean the City of Jeffersonville Wastewater Department
- 6) **Design Engineer**– The engineer sealing the construction plans; this definition is intended to include all employees, sub-contractors and/or agents acting for or on behalf of the Design Engineer.
- 7) **Developer** – The person/company financially responsible for construction activity, or an owner of property who sells or leases, or offers lots for sale in a subdivision; this definition is intended to include all employees, sub-contractors and/or agents acting in the interest of the Developer.
- 8) **Director** – Director of the City of Jeffersonville Wastewater Department, acting directly or through the duly authorized representatives.
- 9) **EDU (Equivalent Dwelling Unit)**: Unit used to calculate the capacity fee or 310 gallons per day.
- 10) **Low Pressure System**: A wastewater collection system in which multiple users pump wastewater into a common force main from individual on-site pumping systems.
- 11) **“Shall”**: is mandatory; **“May”** is permissive.
- 12) **Sidewalk** - The portion of the right-of-way primarily constructed for the use of pedestrians.
- 13) **Specifications and Details** - A general term applied to all directions, provisions, and requirements pertaining to performance of the work.
- 14) **Street** - A general term denoting a public way for purposes of vehicular travel.
- 15) **Subgrade** – The upper portion of a roadbed upon which the pavement structure and shoulders are constructed.

1.5 Permit Applications

Permits for laterals, and sanitary sewer facilities are required to construct, repair, modify, connect, or abandon any lateral or sanitary sewer facility within the City of Jeffersonville.

This does not relieve any person from obtaining any and all applicable approvals and permits from other appropriate regulatory agencies.

The Owner or Developer shall procure at its own expense, all permits and licenses, pay charges and fees, and give all notices necessary and incidental to the due and lawful execution of the work.

Contact the City of Jeffersonville Engineering Department and/or Wastewater Department for all required local permit applications for street, storm, or sanitary sewer construction.

It shall be the responsibility of the Owner whose property is benefited to make all necessary repairs, extensions, relocations, changes, or replacements thereof, and of any accessories thereto for the entire length of lateral, including the portion within public easements and right-of-ways.

These requirements may be altered, modified, or waived, at the discretion of the Department when it is shown compliance is not possible due to extenuating circumstances.

1.6 Expiration of Permit

If construction activity has not commenced **within three hundred sixty-five (365) calendar days** from the date of issuance of the Permit, the Permit shall expire and will no longer be of any force or effect. The Director may however, for good cause shown in a written request to the Department, extend the validity of any such Permit for an additional period which is reasonable under the circumstances to allow commencement of the construction activity. In no event shall the extension exceed a period of **sixty (60) calendar days**.

If the construction activity has commenced, but only is partially completed, and thereafter, no visible construction activity occurs on the construction site over a period of **one hundred eighty (180) calendar days** from the time of the last construction activity, the Permit shall expire and no longer be of any force or effect.

1.7 Payment of Fees

Pursuant to 2025-OR-11 the Owner/Developer shall pay the Capacity and Inspection Fees as follows:

A) Capacity Fee

Prior to the issuance of a preliminary plat, final plat or building permit for any new structure or developments, a sewer Capacity Fee of four thousand nine hundred dollars (\$4,900.00) per Equivalent Dwelling Unit (EDU) shall be levied against a user connecting to the City's sewage works as follows:

1) Calculation of EDU.

- a) Single Family Residence. A single-family residential connection shall equal one (1) EDU.
- b) Non-Residential Users. All other connections shall pay a sewer capacity fee based on the EDUs allocable to the classification of the user connecting to the sewage works. The number of EDUs shall be calculated by the Average Daily Flow (ADF) for the proposed connection as set forth in the most recent version of the Capacity Fee calculations as adopted by the City of Jeffersonville Sanitary Sewer Board as contained in **Appendix A**.

2) Calculation of Sewer Capacity Fee. The sewer capacity fee shall be calculated as follows:

$$\text{Capacity Fee} = \text{Number of EDUs} \times \$4,900 \text{ per EDU.}$$

3) Installment Payments for Proposed Multi-Structures. The Capacity Fee associated with new multi-lot or multi-structure developments within the City of Jeffersonville sewer service area may be paid in installments as follows:

For proposed developments/projects in which the Person wants to reserve capacity for the proposed development/project as contained in the Application for Sanitary Sewer Construction Permit as submitted to the Jeffersonville Sanitary Board, the Person shall pay one-third (1/3rd) of the Capacity Fee attributable to the project or development for which the Application represents.

The City will, upon such payment, certify capacity for those EDUs included in the Construction Permit Application. The Person shall pay the remaining two-thirds of the Capacity Fee at the time the building permit is applied for and issued for each lot or property contained in the Construction Permit Application.

- (d) Previously Approved Projects. Where an individual connection to the sewer system permitted prior to the effective date of this Ordinance is requested, the person requesting the connection shall pay the current Capacity Fee at the time the connection permit is requested and the permit is issued.

In all cases, Capacity Fees shall be nonrefundable and shall remain with the property or improvement for which it was issued and applied.

- B) Change of Use. Any building in which the use of that building is changed where the expected flow will increase as a result of the use change will be subject to a Capacity Fee. The new Capacity Fee will be assessed as follows: The new Capacity Fee will be based on the type of facility as identified in Appendix A. A credit will be given for the Capacity Fee for the existing building.

Example:

If a single-family residence is converted to a 2,500 square foot office then the Capacity Fee will be 2,500 sq.ft. times 0.3 gpd/sq.ft.= 750 gpd – 310 gpd/EDU = 440 gpd. 440 gpd / 310 gpd/EDU = 1.42 EDUs. 1.42 EDUs times \$4,900 = \$6,958. ***The Capacity Fee for the Change of Use is \$6,958.***

- C) Inspection Fee. In addition to the Capacity Fee, a separate sewer tap inspection fee of one hundred dollars (\$100.00) shall be levied against a user connecting to the City's sewage works. The Sewer Tap Inspection Fee shall be paid prior to making the lateral connection to the City of Jeffersonville sanitary sewer facilities.

SECTION 2. SANITARY SEWERS

2.1 General

This section includes specifications for gravity sanitary sewer collection systems, and building laterals.

A) Details

All construction details shall be as shown on “City of Jeffersonville Standard Construction Details,” latest revision. The City Engineer and the Wastewater Department must approve any other alternative method, discrepancy, omission, or duplication of specification standards.

B) Construction Plans

- 1) The plans for the installation of a sanitary sewer system shall be provided by the Applicant and approved by the City Engineer and Wastewater Department. Upon the completion and one week prior to acceptance and unless otherwise approved, the Contractor must submit record drawings certified by a registered Indiana Professional Engineer or Land Surveyor for the installed sanitary sewer system to the Wastewater Department.

C) Standards

- 1) Design, construction, and testing must comply with ASTM and IDEM standards.

D) Responsibilities

- 1) The Owner and/or the Developer shall be responsible for all approvals, permits, and easements.

E) Submittals prior to construction

- 1) The following submittals shall be given to the City’s representative prior to construction:
 - a) Shop drawings for all sanitary sewer materials, including pipe, manholes, pipe couplings, wyes/tees, shall be submitted to the City Engineer/Department at the Pre-Construction Meeting. Shop drawings shall be signed and sealed for compliance to specifications by the Contractor, and, reviewed and stamped by the Project Engineer with comments to the Contractor requiring compliance with Project Plans and Specifications.
 - b) Proposed detailed construction sequence including schedule for bypass pumping and connection to existing sanitary sewer system.
 - c) Permit for excavation within the Right-of-Way, if applicable.
 - d) Copies of Construction Permit and all correspondence concerning deficient plans or approval of plans.

F) Revocation of Permit

- 1) The Wastewater Department may revoke a Permit when:
 - a) The application, plans, or supporting documents contain a false statement or misrepresentation as to a material fact; or
 - b) The application, plans or supporting documents reflect a lack of compliance with the requirements of this Manual; or

- c) Additional information becomes available that would necessitate the revocation of the Permit (Permit issued in error).

G) Stop-Work Order

The Director has the authority to direct the issuance of an order requiring the suspension of the pertinent construction activity ("Stop-Work Order") whenever it is determined that construction activity:

1. Is proceeding in an unsafe manner;
2. Is proceeding in violation of a requirement of this Manual;
3. Is proceeding in a manner which is materially different from the application, plans, or supporting documents; or
4. For which a permit is required is proceeding without such a permit being in force. In such an instance, the stop-work order shall indicate the effect of the order terminates when the required permit is issued.

The Stop-Work Order shall be in writing by the Department and shall state to what construction it is applicable and the reason for its issuance. One (1) copy of the Stop-Work Order shall be conspicuously posted on the property, and one (1) copy shall be delivered via certified mail to the owner of the property or their agent. The Stop-Work Order shall state the conditions under which construction may be resumed.

If a Stop-Work Order is issued, the contractor shall restore the site to a safe condition prior to stopping the work pursuant to the Order.

The sanctions provided in this Section shall in no way limit the imposition of penalties provided elsewhere in this Manual.

H) Submittals prior to City Acceptance

- 1) The following submittals shall be given to and the Wastewater Department prior to City Acceptance:
 - a) Air, mandrel, and vacuum tests.
 - b) CCTV Inspection results on a Flash Drive
 - c) One set of record drawings showing information including, but not limited to, the following: building lateral locations, pipe slopes, invert elevations, top of casting elevations, horizontal locations, and other utility information encountered during construction. Upon completion of all improvements and installations accepted by the City, Digital Plan information and Record Drawings certified by a registered Indiana Professional Engineer or Land Surveyor, unless other submittal requirements are approved by the Department or City Engineer, shall be submitted to the City in .pdf and CAD format (DWG) that is projected into **NAD 1983 State Plane Indiana East FIPS 1301 (US Feet)** coordinate system.

I) Final Acceptance

After all of the documents have been submitted to the Department, an acceptance Letter will be sent to the Owner/Developer formally accepting the sewer as part of the City of Jeffersonville's sewer system

J) Sewer connections

- 1) No sewer connections can be made on any City sewer unless the Property Owners or Developers have the following in their possession:
 - a) Final Acceptance Letter

- b) A valid Building Permit (if applicable)
- c) A Sewer Lateral Connection Permit. All lateral permits issued must have the appropriate street address and/or lot number, as well as the Contractor's name. If the Contractor has not yet been determined, then the Property Owner's name must appear on the permit.

It is the responsibility of the permittee to notify the Department, in the manner described on the Lateral Permit that the lateral is available for inspection.

The Department will conduct inspections on lateral connections from 7:00 A.M. to 4:00 P.M. local time, Monday through Thursday, except for observed City holidays.

- d) A Street-Cut Permit (if applicable)
- 2) *Roof drains, footing drains, sump pumps, and/or surface water drains shall not be connected to the sanitary sewer system, including temporary connections during construction.*

2.2 Design

A) Benchmarks

- 1) Permanent and temporary elevation benchmarks shall be referenced on the plans.

B) All Plans must include the Sewer Service Area

C) All sanitary sewer facilities, both existing and proposed, shall be located to provide adequate access for maintenance and/or repair, and as follows:

1) New Sanitary Sewers

- a) New sanitary sewers shall be constructed within the public right-of-way unless directed otherwise by the Department.

If the right-of-way is not of sufficient width to avoid the granular backfill requirements and the sewer is fifteen (15) inches or less in diameter, the sewer may be constructed outside, but within five (5) feet of, the right-of-way within a fifteen (15) feet wide exclusive sanitary sewer easement dedicated to the City of Jeffersonville and recorded with the County Recorder.

Utilities may encroach into the exclusive sanitary easement, but only for perpendicular crossings (between 45° and 90°). Parallel encroachments (less than 45°) are prohibited without written permission from the Department.

- b) When construction within, or within five (5) feet of, the right-of-way is not possible (i.e. crossing undeveloped off-site areas, etc.), the sanitary sewer shall be located in an exclusive sanitary sewer easement and in such a location to provide adequate access for ease of maintenance and/or repair. The Department will determine if access is adequate. The exclusive easement must be dedicated to the City of Jeffersonville and recorded with the County Recorder.
- c) Sanitary Sewers **shall not be** located in rear yards or other inaccessible areas.

2) Existing Sanitary Sewers

- a) The proposed development shall be configured in such a manner to provide adequate access to all existing sanitary sewers and manholes for ease of maintenance and/or repair. The Department will determine if the site configuration provides adequate access.

Acceptable locations for existing sanitary sewer facilities within proposed developments may be as follows:

- i. Within common areas;
- ii. Within proposed right-of-ways;
- iii. Adjacent proposed right-of-ways provided the existing sanitary sewer is in, and remains in, an exclusive sanitary sewer easement; and/or
- iv. Others as deemed acceptable by the Department.

- b) The proposed subdivision or development shall not be configured in such a manner that would cause existing sanitary sewer facilities to be located in rear yards or other areas determined to be inaccessible by the Department.

3) Adjacent Waterbodies

All sanitary sewer facilities and laterals shall be separated from existing or proposed waterbodies by a minimum twenty (20) feet horizontally as measured from the outside edge of the sanitary sewer facility to the top of bank.

Sanitary sewers, force mains, and laterals crossing existing or proposed lakes, ponds, and/or retention or detention areas (either wet or dry) are prohibited.

D) Pipe Size and Slope

- 1) All sanitary sewer facilities shall be sized to accommodate anticipated flows from upstream service areas. The Property Owner shall contact the Department to determine applicability.
- 2) Gravity sewers shall be sized to maintain a minimum velocity of 2 feet per second.

Gravity sewers shall be a minimum of 8 inches in diameter. Service laterals for residential buildings shall be a minimum of 4 inches in diameter from the building to the property line or Right-of-Way (R/W) and 6 inches in diameter from the property line or R/W to the sewer main.

Non-residential buildings shall be a minimum of 6 inches in diameter and will be approved on a case-by-case basis.

3) Slopes

- a) For gravity sewers, the slopes shall be calculated from center of manhole to center of manhole (not end of pipes). Design slopes above the minimum required slopes are encouraged; however, the gravity sewer pipes shall not be constructed below the following minimum grades:

Size of Sewer	Slope
4-inch (Building Lateral Only)	1.04%
6-inch (lateral from property line to sewer main)	0.61%
8-inch	0.40 %
10-inch	0.28 %
12-inch	0.22 %

15-inch	0.15 %
18-inch	0.12%
21-inch	0.10 %
24-inch	0.08%

Pipes with slopes greater than 20 percent shall be anchored, in accordance with the most recent version of Ten States Standards.

E) Alignment

- 1) Sanitary sewer facilities and water mains shall be laid with at least a 10-foot horizontal separation distance, measured edge to edge. In cases where it is not practical to maintain a 10-foot separation, deviation may be allowed on a case-by-case basis.
- 2) There must be a minimum 18 inches vertical separation between the two pipes for crossings of water mains and sanitary sewer facilities, measured from the outside of the sanitary sewer facility to the outside of the water main. The crossing shall be arranged so that the sanitary sewer facility joints will be equidistant and as far as possible from the water main joints.
- 3) All sanitary sewer facilities shall have a minimum separation from drinking water wells in accordance with the most recent version of Ten States Standards.
- 4) For separations, horizontal or vertical, that are impossible to obtain, both the water main and sanitary sewer facility shall be constructed of ductile iron pipe with mechanical joints complying with public water supply design standards and be pressure tested to 150 pounds per square inch to assure water tightness before backfilling.
- 5) All sanitary sewer facilities shall be a minimum of 10-feet horizontally from top bank of all ditches, creeks, and ponds.
- 6) Castings shall be located so that drainage flows away from the casting.
- 7) From the lowest incoming pipe invert to the outlet pipe invert, there shall be a minimum 0.1 feet in elevation drop. There shall be a maximum 2.0 feet between the highest incoming pipe invert and the outlet pipe invert. Any drops in excess of 2 feet shall require an outside drop manhole structure.

F) Minimum Cover

- 1) Gravity Sewers
 - a) Minimum depth of cover for mainline sewers shall be 36 inches. If the minimum depth cannot be obtained, the mainline gravity sewer shall be Ductile Iron Pipe, class 50, and have a minimum cover depth of 30 inches.

G) Building Lateral Cleanouts

- 1) Sewer main cleanouts are not acceptable for permanent end of runs but are acceptable as temporary for locations between sections of subdivisions.
- 2) A minimum 4-inch diameter for residential and a minimum 6-inch diameter for commercial cleanout shall be located every 100' of lateral length or at any change in direction (at any 45° or 22 1/2° elbow)

H) Elevations

- 1) Finish floor elevations, proposed or existing, for all lots shall be clearly stated. Where the sanitary drainage system of a building can discharge into the sewer by gravity flow, the lowest floor elevation where a plumbing fixture or floor drain is installed must be a minimum of one foot above the top of the crown of the sewer main. Where part of the drainages system cannot be discharged to the sewer by gravity flow, this part of the system shall be discharged to a tightly covered and vented sump from which the contents shall be lifted (pumped) and discharged into the building gravity drainage system a minimum of one (1) foot above the top of the crown of the sewer main.
- 2) Top of castings of all manhole structures shall be at least one foot above the 100-year flood elevation. In areas where this requirement is not met, bolt down castings shall be specified.
- 3) The lowest elevation to receive gravity sanitary service must be one (1) foot above the top of manhole casting elevation of either the first upstream or downstream manhole on the public sewer to which connection is to be made. Those portions of the building not meeting the stated gravity sanitary service requirement shall be provided with a grinder pump system or City approved equal discharging to the gravity building connection outside of the public right-of-way.

I) Manholes

- 1) Maximum distance between manholes shall be as follows:

Sewer Size, inches	Distance Between Manholes, feet
Less than 15	400
15 to 30	500
Greater than 30	600

- 2) Manholes shall be placed where pipe alignment, slope, materials, and/or size changes.
- 3) The angle, between any inlet pipe and the outlet pipe, must be equal to or greater than 90°.
- 4) Minimum manhole diameters shall be as follows as contained in **Table 1**:

TABLE 1	
Pipe Size, inches	Minimum Manhole Diameter, inches
	Pipe Entering / Pipe Exiting at Deflection Angle 90° and greater
8 – 12	48
24	48
27 – 30	60

- 5) Outside drop manholes shall be provided in cases where the invert of any incoming sanitary sewer enters the manhole at elevations greater than twenty-four (24) inches. Inside drop manholes are not permitted.

J) Easements

- 1) Should it be necessary to install gravity sewers outside of public right-of-way, the Owner/Developer will be responsible for providing permanent easements, to be dedicated to the City of Jeffersonville Wastewater Department.

- 2) The minimum required width of the permanent easements for gravity sanitary sewers shall be as follows:
 - a) For sewers with depth of up to 15 feet from finished grade, minimum easement width shall be 15 feet.
 - b) For sewers with depth greater than 15 feet to 25 feet from finished grade, minimum easement width shall be 20 feet.
 - c) For sewers with depth, greater than 25 feet from finished grade, minimum easement width shall be 30 feet.
- 3) All sanitary sewers shall be centered in the easement.

2.3 Materials

A) Gravity Sewers

- 1) PVC pipe diameters of 8 inches through 15 inches shall meet or exceed all the requirements of ASTM D 3034 and shall have a minimum cell classification of 12454 C. Reference should be made to ASTM D 1784 for a summarization of cell class properties. PVC pipe diameters greater than 15 inches shall meet or exceed all requirements of ASTM F 679 and shall have a minimum cell classification of 12454 C.
- 2) The minimum wall thickness of PVC pipe 8 inches through 15 inches in diameter shall conform to SDR 35, type PSM, as specified in ASTM D 3034. The minimum wall thickness for PVC pipe greater than 15 inches shall conform to T 1 as specified in ASTM F 679. PVC pipe shall have a minimum pipe stiffness of 46 pounds per square inch for each diameter when measured at 5 percent deflection and tested in accordance with ASTM D 2412.
- 3) PVC sewer pipe shall meet or exceed all requirements of ASTM F 794 or ASTM F 949 and shall have a minimum cell classification of 12454 C and a minimum uniform pipe stiffness of 50 pounds per square inch for each diameter when measured at 5 percent deflection and tested in accordance with ASTM D 2412.
- 4) Pipe joints shall have a bell wall, gasket groove and spigot which are integral with the pipe. The assembly of joints shall be in accordance with pipe manufacturers' recommendations and ASTM D 3212. Solvent cement joints shall not be allowed.
- 5) Pipe fittings shall be SDR 26 manufactured fittings made of PVC plastic having a cell classification of 12454 B or 12454 C as defined in ASTM D 1784. Saddle connections shall not be allowed for new construction. Lateral connections shall occur at SDR 26 Wyes.
- 6) Each pipe section shall be marked with the name of the manufacturer, trademark or trade name, nominal pipe size, production/extrusion code, material and cell classification, and ASTM number.
- 7) Installation shall be in accordance with ASTM recommended practice D 2321.

B) Building Laterals

- 1) Pipe for residential building laterals shall be a minimum 4-inch PVC from the house to the property line and 6-inch PVC from the property line to the sewer main meeting the requirements of ASTM D3034, SDR35.

- 2) Commercial lateral connections shall be 6-inch PVC meeting the requirements of ASTM D3034, SDR35.
- 3) Pipe shall have a flexible gasket push-on compression type joint. SDR 35 Glue joint pipe may be used on a case-by-case basis.
- 4) Pipe must be laid with the male end of the pipe connecting to the female end in the direction of the flow.
- 5) For residential applications a 4-inch Backflow Valve, Clean Check, Inc. or equal shall be located 3-foot from the building and 6-inch cleanout shall be provided at the property line. For commercial applications the 6-inch Backflow Valve, Clean Check, Inc. or equal shall be installed at a location outside the building to provide for easy access. In addition, all connections to the common lateral serving the building shall be made outside the building. **See Appendix F for details.**

C) Manholes

- 1) Precast concrete manholes shall conform to ASTM C 478 with rubber type gaskets equal to ASTM C 443 and a minimum inside diameter of 48 inches. Monolithic cast-in-place or 'doghouse-type' manholes shall only be used with the prior written approval by the Department. The base and first riser section of the precast concrete manhole shall be integrally cast as one unit. Precast concrete cones shall be of the eccentric cone type. No "see through" lift holes shall be allowed on precast concrete manholes 48 inches in diameter. In addition to the rubber type gaskets, all joints shall receive a 1/2-inch diameter non-asphaltic mastic (Kent-Seal or as approved by the City), conforming to ASHTO M198 and federal specifications SS-S-210A. Sewer connection to manhole shall be Kor-N-Seal, A-Lok, Dura-Seal or as approved by the City.
- 2) Where one solid riser or barrel section cannot be used, final adjustment in elevation of the frame and cover shall be accomplished by the use of a 4-inch minimum thickness adjusting ring to a maximum combined thickness of 12 inches. Brick or block shall not be used in the construction of a manhole or to adjust the elevation of the frame and cover. For situations that require a riser thickness of less than four (4) inches will be approved on a case-by-case basis. Non-hardening butyl rubber sealant shall be installed between cone, riser rings, and casting. Sealant shall meet or exceed ASTM 0990-94.
- 3) **The manholes shall not contain any steps.**
- 4) A 6-inch minimum width of butyl rubber coating on the exterior of the manhole shall be applied at each joint to prevent leakage.
- 5) Precast flow channel through manholes shall be U-shaped at a minimum width and depth equal to the diameter of the pipe extending between the pipe inverts. The bench walls must extend up from the flow channel to an elevation that creates a one-inch per foot minimum slope with the inner wall of the manhole section and shall have a slick finish.
- 6) Manhole covers shall be Type "A" cast iron ring and cover and must conform to ASTM A 48. All sanitary manholes that lay along a stream, swale, or open storm channel shall have locking or bolt down lids with an inside seal between the lid and casting. Sanitary manholes are not permitted to be located in a stream, or in the flowline of a swale, or open storm channel. Manhole lids shall be stamped "CITY OF JEFFERSONVILLE SANITARY SEWER." Casting shall be East Jordan Ironworks 1045 casting and 1040 AGS lid, Neenah R1642, or equivalent with a self-sealing machined lid.

D) Bedding and Backfill

- 1) Contractor shall comply with Bedding and Backfill requirements as required by the City of Jeffersonville Construction Standard Details Sheets.

2.4 Execution

A) Pre-Construction Conference

- 1) Before the start of any construction on the project site, a conference must be scheduled and completed with the City Engineer and the Wastewater Department.

B) Permits

The Contractor or the Property Owner must obtain a lateral connection permit before a sewer connection can be made.

C) Utility Locations

- 1) The Contractor is responsible for determining the location of existing utilities 48 hours prior to any construction or excavating per Indiana 811 requirements.
- 2) A tracer wire must be installed on all lateral connections with the wire exposed/connected to the cleanout.

D) Benchmarks

- 1) Benchmarks shall be referenced to the North American Vertical Datum of 1988 (NAVD 88) and be related to existing monuments that have been published by MGD, USC&GS, USGS, or IDNR, Division of Water.
- 2) Benchmarks shall have at least one benchmark per site or more if appropriate, using monuments that are of good construction (i.e. pin in concrete, railroad spike or nail in utility pole, or chiseled mark on a stable concrete structure).

E) Building Laterals

- 1) Tight fitting, PVC caps shall be installed on the end of each lateral stub. Also, a metallic marker must be placed at the end of each lateral for future locating.
- 2) Lateral connections to the mainline sewer must be wye connections; no saddle connections will be allowed.
- 3) InsertaTEE™ or InsertaWYE™ shall only be used on a case-by-case basis when approved by the Wastewater Department
- 4) A 12-gauge stranded wire shall be installed (taped) on the top of the pipe along the entire length of the lateral from the sewer to the 4-in cleanout located near the building. All wire-to-wire connections will be joined using a DBR Direct Burial Splice Kit as manufactured by 3M Electrical Products Division or a Department approved equal.
- 5) No lateral shall directly discharge to a manhole unless approved by the City Engineer or the Wastewater Department.

- 6) **Sewer laterals, under no condition shall be backfilled until the Wastewater Department's representative has inspected and approved all work.**
 - 7) Turns made in lateral alignment shall be accomplished by utilizing 22° and/or 45° elbow fittings with a cleanout located at each elbow, if required based on circumstances of the project. **The utilization of 90° elbow fittings is not permitted.**
 - 8) At the discretion of the Department, the lateral sewer may be required to be pressure or smoke tested and/or televised before approving the connection.
- F) Manholes
- 1) Manholes shall be placed on a minimum 12 inches of INDOT No. 8 crushed stone that has been mechanically compacted. Where unstable or poor soil conditions exist, the contractor/owner shall have a geotechnical engineer provide recommendations on how to stabilize the unsuitable soil. The remainder of the manhole shall be backfilled using INDOT No. 8 stone. Stone shall be placed in 6-inch lifts and mechanically compacted to 95 percent maximum dry density as determined by ASTM D 698.
 - 2) Joint seal system (Kent-Seal or as approved by City) shall be installed using the Manufacturers written instructions. The top of the manhole casting and cone section shall be joint-sealed with inspection prior to backfilling.
 - 3) Connections to all manholes, new or existing, shall be core drilled and booted. These taps shall be cored into the manhole between the spring line of the sewer or no more than 24 inches above the flow line. Manhole connections shall not protrude past the interior of the wall of the manhole. All pipe connections to the manhole shall not be grouted to verify watertight installation.
 - 4) Drop manholes shall be either precast or cast-in-place exterior drop manholes. *Internal drop may be allowed on a case-by-case basis.*
 - 5) All sanitary manholes shall be vacuum tested with castings per ASTM C 1244 following full installation.
- G) Drainage
- 1) **Roof drains, footing drains, sump pumps, and/or surface water drains shall not be connected to the sanitary sewer system, including temporary connections during construction.**
- H) Backfill
- 1) Bedding and backfill dimensions shall have a minimum trench width as designated on the standard construction details.
 - 2) Fill placed under any street or sidewalk shall be compacted to 95 percent maximum density as determined by ASTM D 1557.
- I) Safety and Spills
- 1) CONTRACTORS ARE SOLELY RESPONSIBLE FOR ALL SEWAGE SPILLS that occur as a result of their work. The Contractor must have an action plan to anticipate problems connecting to existing sewers and pumping sewage around a work site.

- 2) CONTRACTORS ARE RESPONSIBLE FOR SAFETY AT THE JOB SITE. They shall make provisions for a safe working environment for their own crews, as well as City personnel and inspectors. The project site shall be in compliance with all OSHA safety regulations, including but not limited to construction trench safety and confined safety entry regulations.
- 3) Should unknown active utilities be damaged during excavation work, work must be stopped immediately. Do not proceed with work until decision has been reached regarding repair, removal, or relocation of utilities. The Contractor must give notice to the appropriate utility.

J) Testing

1) Leakage Testing

- a) The City shall be given 24 hour written notice of the required leakage testing procedure to be performed by the contractor. Contractor shall utilize a liquid-filled gauge for pressure measurements in test. Low pressure air shall be slowly introduced into the sealed line until the internal air pressure reaches 4 PSIG plus the groundwater head divided by 2.31 (maximum test pressure is 9 PSIG).
- b) At a stable internal air pressure within 0.5 PSIG of the initial internal air pressure, timing shall commence with a stopwatch or similar device of 99.8 percent accuracy. Timing shall end when the internal air pressure drops 1 PSIG below the stable internal air pressure.
- c) The line shall be accepted if the time shown in **Tables 2, 3, and 4** for the designated pipe size and length elapses before the air pressure drops 1 PSIG below the stable internal air pressure at which time the test can be discontinued for the accepted line.
- d) These tests shall be observed and certified by a representative of the City on the form contained in **Appendix B**.
- e) In areas where groundwater is known to exist, the Contractor and Engineer shall determine the extent of groundwater over the invert of the pipe and apply additional pressure to the test pressure as follows. In no case should the starting test pressure exceed 9.0 psig.

TABLE 2	
Extent of groundwater over invert of pipe	Pounds of pressure to be added to test pressure
1 foot	0.5
2 feet	0.8
3 feet	1.3
4 feet	1.7
5 feet	2.1
6 feet	2.6
8 feet	3.4
10 feet	4.3
12 feet	5.2

TABLE 3	
If the pressure does not fall below 2.5 psi from 3.5 psi in the following situations, the pipe will be accepted. The length of pipe shall be any length between manholes.	
Size (inches)	Time allowed for pressure to drop from 3.5 to 2.5 psi
6	3 minutes
8	4 minutes
10	5 minutes
12	5-1/2 minutes
15	7-1/2 minutes
18	8-1/2 minutes
21	10 minutes
24	11-1/2 minutes
27	13 minutes
30	14-1/2 minutes
33	15-1/2 minutes
36	17 minutes

TABLE 4	
If the pipe does not meet the above test, the time shall be computed by the following expression: $t = k / c$	
where t =	time in seconds for air pressure inside of pipe to decrease from 3.5 to 2.5 psi
k =	$0.011 \times d^2 \times L$
c =	$0.0003883 \times d \times L$ (if c is 1, or less, use value of 1 for c)
d =	inside pipe diameter of pipe under test (inches)
L =	length of pipe under test (feet)

2) Mandrel Testing and Televising

- a) A 5 percent "GO-NO-GO" Mandrel Deflection Test shall be performed on all gravity sanitary sewer pipes.
- b) These pipes shall be mandrelled with a rigid device sized to pass 5 percent or less deflection (or deformation) of the base inside diameter of the pipe. The mandrel test shall be conducted no earlier than 30 days after reaching final trench backfill grade, provided that in the opinion of the Department or City Engineer sufficient water densification or rainfall has occurred to thoroughly settle the soil throughout the entire trench depth. If densification, in the opinion of the Department or City Engineer, has not been achieved within the 30-day time frame, the mandrel size shall be increased to measure a deflection limit of 3 percent.

- c) The mandrel (GO-NO-GO) device shall be cylindrical in shape and constructed with 9 or 10 evenly spaced arms or prongs. Mandrels with fewer arms shall not be allowed due to being insufficiently accurate. The mandrel diameter dimension "D" shall be equal to the inside diameter of the sanitary sewer. Allowances for pipe wall thickness tolerances or ovality (from heat, shipping, poor production, etc.) shall not be deducted from the "D" dimension, but shall be counted as part of the 5 percent or lesser deflection allowance. Each pipe material/type required to be Mandrel tested shall be tested with a mandrel approved by the pipe manufacturer and meeting the requirements of this Section. The "D" mandrel dimension shall carry a tolerance of +/-0.01 inches.
- d) The mandrel shall be pulled in a manner acceptable to the Department through all sewer lines and any section or sewer not passing the mandrel shall be uncovered, replaced or repaired to the Department's satisfaction and retested.
- e) The contact length (L) shall be measured between points of contact on the mandrel arm. The length shall not be less than as shown on **Table 5** below:

TABLE 5			
9 Arm Mandrel Deflection			
D DIMENSIONS FOR ASTM 3034 - SDR 35 Sewer Pipe			
Nominal Diameter (inches)	Length (inches)	3% Deflection (in)	5% Deflection(in)
8	8	7.71	7.56
10	10	9.63	9.45
12	10	11.46	11.26
15	12	14.03	13.78
10 Arm Mandrel Deflection			
D DIMENSIONS FOR ASTM D3034 - SDR 35 Sewer Pipe			
Nominal Diameter (inches)	Length (inches)	3% Deflection (inches)	5% Deflection (inches)
8	8	7.71	7.58
10	10	9.65	9.48
12	10	11.48	11.29
15	12	14.06	13.82

- f) Contractor shall provide proving rings to check the mandrel. Drawings of mandrels with complete dimensions shall be furnished by the Contractor to the City upon request for each diameter and specification of pipe.
- g) Testing Form: Contractor must submit the results of the mandrel test on the form in **Appendix C** with the following information:
 - Project Name
 - Contractor
 - Date of Test
 - Manhole ID numbers
 - Diameter of Sewer (Inches)

- Type of Mandrel (9-arm, 10-arm)
- Proving Ring Check (serial number of proving ring)
- Pass/ Fail
- Testing Operator's Signature
- Wastewater Department's Representative's Signature

3) Manhole Testing

- a) All manholes must be vacuum tested after installation, repair or modification.
- b) The City may require additional vacuum tests if the manhole casting is not bolted to the structure prior to the test.
- c) Manhole boots must be secured to prevent movement while the vacuum is drawn.
- d) Installation and operation of vacuum equipment and indicating devices must be in accordance with manufacturer's recommendations and performance specifications that have been provided by the manufacturer and accepted by the Wastewater Department.
- e) All manholes shall be negative air pressure (vacuum) testing methods in accordance with ASTM C1244-93. These tests shall be performed by the Contractor and observed and confirmed by a representative of the Department.
- f) Stub outs, manhole boots and pipe plugs must be secured to prevent movement while the vacuum is drawn.
- g) Installation and operation of vacuum equipment and indicating devices must be in accordance with manufacturer's recommendations and performance specifications that have been provided by the manufacturer and acceptable to the City.
- h) Procedures: With the vacuum tester set in place:
 - i.) Inflate the compression band to 40 psi to affect a seal between the vacuum base and the structure.
 - ii.) Connect the vacuum pump to the outlet port with the valve open.
 - iii.) Draw a vacuum 10" of Hg. and close the valve.
- i) Acceptance standards for leakage will be established from the elapsed time for a negative pressure change from ten (10) inches to nine (9) inches of mercury. The maximum allowable leakage rate for a four-foot diameter manhole must be in accordance with **Table 6** below:

TABLE 6			
Manhole Depth	Minimum Elapsed time for a Pressure Change of 1 Inch HG		
	<i>Four (4) foot Manhole</i>	<i>Five (5) foot Manhole</i>	<i>Six (6) foot Manhole</i>
10 feet or less	60 seconds	75 seconds	90 seconds
>10 feet <15 feet	75 seconds	90 seconds	105 seconds
>15 feet <25 feet	90 seconds	105 seconds	120 seconds

For all manholes deeper than 25 feet, the City Engineer will determine the applicable minimum elapsed time.

- j) Retest:
 - i.) If the manhole fails the test, necessary repairs must be made and the vacuum test and repairs must be repeated until the manhole passes the test.
 - ii.) If manhole joint seals are pulled out during the vacuum test, the manhole must be disassembled and the joints replaced.
- k) Visual:
 - i) Manholes will be subject to visual inspection with all visual leaks being repaired.
- l) Testing Form:
 - i) Contractor must submit the results of the vacuum test on the form in **Appendix D** with the following information:
 - Date of Test
 - Project Name and Contractor
 - Manhole ID number, Diameter, and Depth
 - Test Duration (Seconds) and Pressure Drop (Inches of Mercury)
 - Pass/ Fail
 - Testing Operator's Signature
 - Engineer's Representative Signature
- 4) Closed Circuit Television (CCTV) Inspection
 - a) All sections of the new sewer will be inspected by closed circuit television. All television inspections must be performed in a manner acceptable to the Wastewater Department.
 - b) The Contractor must furnish all equipment, a qualified television technician, trained supervisor and sufficient personnel to perform all the work required in the inspection operation.
 - c) The Contractor must furnish spare cameras and related equipment to prevent delays due to equipment breakdowns. Cameras must be equipped with remote-control focusing devices, remote-control devices to adjust the light intensity and enough cable must be furnished to inspect one thousand (1,000) lineal feet of sewer in a continuous operation. The camera must be small enough to pass through a six (6) inch opening.
 - d) The Contractor must clean the sewer at the discretion of the Wastewater Department., when required, one section at a time After the sewer is cleaned, the television camera must be attached to the end of a cable so that it can be pulled through the pipe. The camera must trail a line of steel cable which will be attached to a winch of sufficient size to be able to pull back or retrieve the camera whenever necessary.
 - e) The camera must transmit a continuous color image to the color television monitor. This image must be clear and sharp enough to enable those viewing the monitor to be able to easily see the interior condition of the pipe being inspected. A continuous distance log, zeroed at the starting manhole, must be displayed on the monitor at all times.
 - f) The Contractor must furnish all equipment required for making a continuous Digital copy of the view which appears on the monitor.

- g) The Wastewater Department's representative must be present at all times during television inspection of the sewers and will indicate to the Contractor whatever data is required to be logged and prepared for record purposes. The Contractor must prepare and furnish to City of Jeffersonville Wastewater Department and the Developer not less than two (2) copies of the final record, Flash Drive and report of all inspection work done.
- h) Final Inspection

Prior to conveyance, the City of Jeffersonville Wastewater Department will conduct an inspection ("Final Inspection") which will consist of a walk-through of the completed project.
- i) After the Final Inspection has been performed, the City of Jeffersonville Wastewater Department will provide a written summary, or punch list, of items which require corrective action. Developer must complete all punch list items within forty-five (45) days from the date of issuance of the punch list.
- j) Developer must rectify all defects identified during the Final Inspection in a manner acceptable to The City of Jeffersonville prior to Sanitary Sewer Facilities being conveyed to Jeffersonville.
- k) After Final Inspection, if during the construction individual building(s), there is damage to the existing previously approved sanitary structures, the necessary repairs will be made at the responsible party's expense.

SECTION 3. SANITARY SEWER LIFT STATION/FORCE MAIN

3.1 General

This section includes specifications for sanitary sewer pump station/ force main systems.

A) Details

- 1) All construction details shall be as shown on “City of Jeffersonville Standard Construction Details,” latest revision. The Department must approve any other alternative method, discrepancy, omission, or duplication of specification standards.

B) Construction Plans

- 1) The plans for the installation of a sanitary sewer system shall be provided by the Applicant and approved by the Department. Upon the completion and one week prior to acceptance, the Contractor must submit record drawings certified by a registered Indiana Professional Engineer or Land Surveyor for the installed sanitary sewer system to the City.

C) Standards

- 1) Design, construction, and testing must comply with ASTM and IDEM standards.

D) Responsibilities

- 1) The Property Owner/Developer shall be responsible for all approvals, permits, and easements.

E) Submittals prior to construction

- 1) These submittals shall be given to a City representative prior to construction:
 - a) Shop drawings for all sanitary sewer materials, including pipe, pipe couplings, wyes/tees, pump station structures and equipment, air release valve cleanout structures/equipment shall be submitted to the Department. Shop drawings shall be signed and sealed for compliance to specifications by the Contractor, and, reviewed and stamped by the Project Engineer with comments to the Contractor requiring compliance with Project Plans and Specifications.
 - b) Proposed detailed construction sequence including schedule for bypass pumping and connection to existing sanitary sewer system.
 - c) Permit for excavation within the Right-of-Way, if applicable.
 - d) Copies of the Construction Permit and all correspondence concerning deficient plans or approval of plans.

F) Submittals prior to City Acceptance

- 1) These submittals shall be given to a Department’s representative prior to City Acceptance:
 - a) Hydrostatic, vacuum, and pump-down tests. The pump-down test must be performed by a representative of the pump supplier or the pump manufacturer.
 - b) One set of record drawings showing information including, but not limited to, the following: building lateral locations, invert elevations, top of casting elevations, horizontal locations, and

other utility information encountered during construction. Upon completion of all improvements and installations accepted by the Department, Digital Plan information and Record Drawings certified by a registered Indiana Professional Engineer or Land Surveyor unless other submittal requirements are approved by the Department or City Engineer, shall be submitted to the City in .pdf and CAD format (DWG) that is projected into **NAD 1983 State Plane Indiana East FIPS 1301 (US Feet)** coordinate system.

G) Operation and Maintenance Manuals

- 1) Two (2) operation and maintenance manuals and a digital copy shall be submitted to the City of Jeffersonville
- 2) Manuals shall include, at a minimum:
 - Operation instructions
 - Maintenance instructions
 - Recommended spare parts list
 - Lubrication schedules
 - Structural diagrams
 - As-built wiring diagrams
 - Bill of materials

H) Pump warranty, provided by the pump manufacturer, shall be submitted to the City of Jeffersonville Wastewater Department for review and approval. The pump warranty shall warrant the units being supplied to the Owner against defects in workmanship and materials for a period of five (5) years under normal use, operation and service. The warranty shall be in printed form and apply to all similar units.

3.2 Design

A) Benchmarks

- 1) Permanent and temporary elevation benchmarks shall be referenced on the plans.

B) Location

Lift station locations will be evaluated by the Department on a case-by-case basis.

C) Force Main Size

- 1) Force mains shall be sized to maintain a minimum cleansing velocity of 2 feet per second.
- 2) Velocities in force mains greater than eight (8) ft/s are not acceptable.
- 3) Force mains shall be a minimum of 4 inches in diameter unless otherwise approved by the Department.

Minimum acceptable force main diameter, for use with grinder pumps, shall be two (2) inches.

- 4) “Common force main systems” will not be permitted. “Low pressure force main systems” will be reviewed by the City/Department on a case-by-case basis.
- 5) Force mains shall be designed to resist hydraulic forces and prevent water hammers.

D) Alignment

- 1) Sanitary sewer facilities and water mains shall be laid with at least a 10-foot horizontal separation distance, measured edge to edge. In cases where it is not practical to maintain a 10-foot separation, deviation may be allowed on a case-by-case basis.
- 2) There must be a minimum 18 inches vertical separation between the two pipes for crossings of water mains and sanitary sewer facilities, measured from the outside of the sanitary sewer facility to the outside of the water main. The crossing shall be arranged so that the sanitary sewer facility joints will be equidistant and as far as possible from the water main joints.
- 3) All sanitary sewer facilities shall have a minimum separation from drinking water wells in accordance with the Ten States Standards, current version.
- 4) All sanitary sewer facilities shall be a minimum of 10-feet horizontally from top bank of all ditches, creeks, and ponds.
- 5) Castings shall be located so that drainage flows away from the casting.

E) Minimum Cover

- 1) A minimum depth of cover for force mains shall be 36 inches.

F) Elevations

- 1) Force main high points: Air/vacuum relief valves shall be e A.R.I. Model D-025, or equal located at all high points along the force main. Additional valve placement may be required as directed by the Department.
- 2) Force main low points: Clean out valves shall be located at all low points along the force main. Additional valve placement may be required as directed by the City Engineer and/or the Wastewater Department.

G) Lift Station Structures and Equipment

- 1) Sanitary sewer lift stations will be permitted only upon the submittal of an economic analysis to the City Engineer, proving to the satisfaction of the City Engineer and the Wastewater Department that the pump station exhibits a lower 50-year life cycle cost than that of a gravity sewer or if a gravity sewer cannot be constructed due to geographical limitations.
- 2) Design Engineer shall obtain approval on pump station /force main design prior to construction. Design Engineer shall submit the following documentation to the Jeffersonville City Engineer for review and approval:
 - a) Project plans and specifications
 - b) Force main head calculations.
 - c) Plots of pump curve and system curve, provided in feet of total dynamic head (TDH) versus gallons per minute of flow, with complete force main head calculations supporting curves.
 - d) Wet well detention/float setting calculations.

- e) Buoyancy calculations for all pump station structures. Minimum safety factor of 2.0 shall be utilized.
- 3) All wet wells shall be designed for ultimate peak flow in accordance with flows required by Jeffersonville City Engineer.
- 4) High water alarm shall be six inches below flow line of the lowest incoming pipe.

H) Easements

- 1) The developer will be responsible for providing a permanent easement for the placement of the pump station, to be dedicated to the City of Jeffersonville. The dimensions and boundaries of the easement shall be approved by the Jeffersonville City Engineer and the Wastewater Department.
- 2) Should it be necessary to install force mains outside of public right-of-way, the developer will be responsible for providing permanent easements, to be dedicated to the City of Jeffersonville Wastewater Department.
- 3) The permanent easements for force mains shall have a minimum width of 15 feet.
- 4) All force mains shall be centered in the easement.

3.3 Materials – Submersible Lift Station Structures and Equipment

A) General Requirements

- 1) Furnish all labor, equipment and material to construct a submersible pumping station consisting of pumps, motors, wet well, separate valve vault, separate meter pit, valves, piping, hatches, guide rails, pump removal components, control center, mercury float switches, remote monitor package, interconnecting electrical wiring, incoming power supply, one-inch frost free yard hydrant and all other features regularly and normally required as a part of a complete and functional facility. All work to be in accordance with site requirements, details in the plans, these specifications and the manufactures recommendations.
 - 2) All of the mechanical and electrical equipment shall be an integral package supplied by the pump manufacturer with local representation so as to provide undivided responsibility. The package shall be equal in construction and performance to KSB, Myers or Flygt (Xylem) equipment and other specific requirements set forth herein and in the approved plans.
 - 3) All non-metallic force mains (PVC, HDPE) shall have a 12-gauge shielded copper tracing wire placed directly above the pipe. The wire must be accessible at valve vaults and manholes.
 - 4) Any exceptions to this specification or associated approved plans shall be submitted in writing and clearly stated. The exceptions must be approved by the Project Engineer and the City of Jeffersonville prior to proceeding with work.
 - 5) All components of the pump station that are exposed to weather shall be constructed of material that is resistant to corrosion throughout the expected life of the pump station. In general, these materials are stainless steel, aluminum, fiberglass reinforced polyester (FRP) and ultraviolet stabilized PVC.
- B) Operating Conditions of pump station shall be determined by the Project Engineer and approved by the City of Jeffersonville.

C) Pumping Equipment:

- 1) Pumps shall be of the submersible type, explosion-proof for handling raw unscreened sewage. Pump volute, motor and seal housing are to be high quality gray cast iron. Impeller shall be either cast iron or cast bronze of a non-clog design capable of handling minimum 3-3/4" sphere solids, fibrous material, heavy sludge and other matter found in normal sewage applications. Impeller shall have pump out vanes on the back shroud of the impeller to keep pumped material away from the seal area and increase operating life. Impeller shall be either slip fit or taper fit with key to securely lock the impeller to the driving shaft. The pump volute shall be fit with a replaceable bronze wear ring to minimize wear on the impeller and help achieve longer balanced operating life. All fasteners shall be of stainless steel. The City of Jeffersonville provides an option, upon request by the City Engineer and/or Department, for the project pump specifications to provide "cutter" or "chopper" type pumps, based on the quantity of fibrous materials in the raw wastewater accepted by the proposed pump station.
- 2) All mating surfaces where water tight sealing is required shall be machined and fitted with nitrile rubber O-rings. Sealing shall be accomplished when metal-to-metal contact is made, resulting in controlled compression of the rubber O-rings without requirement of a specific torque limit.
- 3) The pump shall be provided with a mechanical rotating shaft seal system running in an oil reservoir having separate, constantly lubricated lapped seal faces. The lower seal unit between the pump and oil chamber shall consist of one (1) stationary seat and one (1) rotating ring held in place by its own spring. The lower seal shall be removable without disassembling the seal chamber. The upper seal between the motor and the seal chamber shall be of the same design with its own separate spring system. The seals shall require neither maintenance nor adjustment, but shall be easily inspected and replaceable. Seal shall be fitted on a 303 stainless steel shaft sleeve. Shaft seals with conventional double seal utilizing a single spring between the two seals and requiring a pressure differential to offset external pressure shall not be considered acceptable nor equal to the dual independent seal system specified. The shaft sealing system shall be capable of operating submerged to pressures equivalent to two hundred (200) feet. No seal damage shall result from operating the pump unit out of its liquid environment. The seal system shall not rely upon the pumped media for lubrication. The seal chamber shall also be equipped with a seal failure sensor probe which will sense water intrusion through the lower seal. This sensor is to be connected to an alarm in the control panel to indicate lower seal failure.
- 4) The stator winding, rotor and bearings are to be mounted in a sealed submersible type housing. Insulation utilized in the stator windings shall be class F with maximum temperature capability of 155 degrees Centigrade. Motor housing shall be filled with a high-dielectric oil to give superior heat transfer and allow the bearings to run in a clean, well lubricated environment; or the housing shall be air filled with grease lubricated bearings. The pump and motor are to be specifically designed so that they may be operated partially or completely submerged in the liquid being pumped. The pump should not require cooling water jackets. Stators shall be securely held in place with a removable end ring and threaded fasteners so that it may be easily removed in the field without use of heat or a press.

Shaft shall be of stainless steel and supported by ball bearings. Motor shall be provided with heat sensing units attached to the motor windings, which shall be connected to the control panel to shut down the pump if overheating occurs.

- 5) Pump motor cable and heat sensor /seal failure sensor cable shall be suitable for submersible pump applications and this shall be indicated by a code or legend permanently embossed on the cable. Cable sizing shall conform to NEC specifications for pump motors and shall be of adequate size to allow motor voltage conversion without replacing the cable. Cable of the proper length shall be provided to eliminate the need for splices or junction boxes between pump and 'Control Center'.

The cable shall enter the motor through a cord cap assembly which is double-sealed allowing disassembly and disconnect of the wires at the motor and still not damage the sealed characteristics of the motor housing.

- 6) The pump mounting base shall include adjustable guide rail supports and a discharge connection with a one hundred twenty-five (125) pound standard flange. The base and the discharge piping shall be permanently mounted in place. The base plates shall be anchored in place utilizing epoxy type anchors with stainless steel studs and nuts as manufactured by HILTI Fasteners, Inc.
- 7) All piping inside pump station wet well, valve vault and meter pit structures shall be ductile iron pipe, and extended ten feet outside of each structure, in accordance with the ductile iron force main pipe section of these Standards.
- 8) A rail system shall be provided for easy removal of the pump and motor assembly for inspection and service. The system shall not require a man to enter the wet well to remove the pump and motor assembly. Two (2) rails of two (2) inch stainless steel pipe shall be provided for each pump. The guide rails shall be positioned and supported by the pump mounting base. The guide rails shall be aligned vertically and supported at the top by an attachment to the access hatch frame. One (1) intermediate guide rail support is required for each fifteen (15) feet of guide rail length for stainless steel pipe.
- 9) The pumps shall be equipped with sliding brackets or rail guides. To insure easy removal of the pumps, the rail guides attached to each pump shall not encircle the rails. A stainless-steel lifting chain of adequate length for the wet well depth shall be provided for each pump.
- 10) The rails and rail guides shall function to allow the complete weight of the pumping unit to be lifted on dead center without binding and stressing the pump housing. The rail system shall function to automatically align the pumping unit to the discharge connection by a simple downward movement of the pump. No twisting or angle approach will be considered acceptable. The actual sealing of the discharge interface will be a metal face such as Myers, KSB or Flygt.

D) Wet Well, Valve Vault, Meter Pit and Accessories:

- 1) The wet well, valve vault, and meter pit are to be constructed of precast concrete. The actual arrangement of the structures is to be as shown in the approved plans. The wet well top shall be provided with a four (4) inch PVC vent having a downward pointing inlet and screen over the inlet opening. The City of Jeffersonville provides an option, upon request by the Department, for the project specifications to require a carbon filter on the vent based on the need for odor control.
- 2) The wet well, valve vault, meter pit, flat tops and base slabs are to be constructed of precast reinforced concrete manhole sections conforming to ASTM C-478. All joints between precast sections shall be made with an approved rubber O-ring in accordance with ASTM C-443. In addition, the outside wall below grade is to be coated with bituminous waterproofing material. The top and bottom of the chambers shall be precast or may be poured in place concrete if approved by the Project Engineer and the Department. An OSHA compliant aluminum ladder with Bilco Ladder-Up steps shall be provided in the valve vault and meter pit only.
- 3) The pump supplier shall to provide an aluminum two (2)-door (for duplex pump station), or, three (3)-door (for triplex pump station) access hatch frame and door assembly to be installed in the concrete wet well top. This door assembly shall provide access for removal of the pumps and shall support the guide rails. Hatch size to provide a minimum clearance of 6" from any obstructions when removing the pump. The doors shall be provided with lifting handle, safety latch to hold door in the open position and a hasp suitable for a padlock. The doors shall have a non-skid finish. The hatch shall be Bilco or equal with Fall Protection Grating as part of the unit. Hatch and Fall Protection

Grating to hinge in a direction to not limit or impede access to the level controls or removal of the pump.

- 4) An aluminum single door access hatch frame and door assembly, similar to the one described above, shall be provided for use as entry to the valve vault, bypass vault and the meter pit. Minimum opening for the valve box entry shall be thirty-six (36) inches by thirty-six (36) inches. The valve vault door shall be offset over the ladder provided in the valve vault and meter pit.
- 5) A check valve (APCO Valve Series 6000 weighted check or City-approved equal) and an eccentric plug valve (Clow Corporation Valve Division, or City- approved equal) shall be installed in the valve vault in each pump's discharge piping. All piping from pump base elbows, through the valve vault and exiting the valve vault shall be ductile iron. All elbows, tees and cross piece fittings shall be ductile iron. A PVC drain pipe and check valve shall be installed to drain the valve vault back to the wet well.
- 6) An additional eccentric plug valve (Clow, or City- approved equal) shall be provided in the valve vault to allow access to the force main for bypass pumping. The bypass valve shall have an upward directed elbow and a 4", 6" or 8" (to match the size of the force main) female aluminum Bauer style fitting with cap to allow attachment of City owned bypass pumping equipment
- 7) Plug valves to be positioned so that they may be turned from grade level with a T-handle wrench

E) Emergency Pump Connection Manhole

- 1) An emergency pump auxiliary connection and manhole shall be provided at all Lift Stations. The structure shall be a precast manhole (5' minimum diameter) with a 8" thick precast concrete lid (ASTM C478 LR) With an aluminum single door access hatch frame and door assembly, similar to the one described above in section D) 3 & 4.
- 2) This connection shall allow bypass pumping of the wet well during emergency conditions. The pipe shall extend a minimum of one (1) foot above the lid, turned 90° to the hose connection. The emergency connection with a Bauer fitting and shall be the same size as the force main with a female fitting.

There shall be a plug valve installed on the pipe to allow bypassing when necessary, a two (2) inch pipe with valve from the piping to the wet well for pipe drainage and a 2" PVC pit drain from this structure to the valve vault.

F) Disconnect Switches and Conduit:

- 1) A single main fusible or breaker disconnect switch of adequate size to provide power for the Pump-Control Panel and its related components shall be provided by the Contractor.
- 2) The disconnect switch shall be housed in a NEMA 4X stainless steel enclosure with an external operation handle capable of being locked in the ON position.
- 3) Manual Transfer Switch – The contractor shall supply and install a three way switch lockable in all positions for the City's emergency generator. A fusible disconnect switch between the transfer switch and the generator plug shall be located in a NEMA 4X box. The Design Engineer shall coordinate with the Jeffersonville City Engineer to provide compatibility of switch and cable with the City's generator. The City Engineer and/or Department will have the option to specify onsite emergency generator set for the project pump station.

- 4) Power and sensor wires from the pump J-box at the wet well shall be run in Schedule 40 PVC conduit to the Pump Control Panel. For VFD-controlled pumps, where the VFD's are not located in the Pump Control Panel, run the sensor wires in separate conduit directly to the Pump Control Panel if possible. Run the power wires in separate conduit to the VFD's. Care must be taken to separate the sensor wires from the power wires. Any shields around VFD power or signal cables must be grounded. Level transducer and float wiring shall be run in a conduit or conduits separate from pump power or sensor wiring.

G) Pump-Control Panel:

- 1) The pump-control panel enclosure shall be NEMA 4X, stainless steel when located outdoors. For indoor installations NEMA 12 will suffice. It shall be suitable for the specified horsepower and voltage of the pumping equipment. The outer door shall be a hinged dead front with provision for padlocking. There shall be a separate inner door for pilot devices, with cutouts that allow access to circuit breaker actuators. Provide 20% usable spare space for future modifications.
- 2) There shall be a separate circuit breaker or Motor Circuit Protector for each pump, and a separate 2-pole, D-curve breaker to provide primary power to a control transformer with 120V secondary. Install a 3-phase surge suppressor in the panel across the incoming power lines.
- 3) A phase monitor, protected by a separate 1-Amp, 3-pole breaker, will interlock pump operation. It should connect to a relay in the control circuit, whose contacts will interlock pump operation, and provide a "Power OK" signal to the PLC. In the case of a project using remote-mounted VFD's, the pump control panel will not be connected to 3-phase power. In that case, no phase monitor will be required in the control panel.
- 4) The control transformer must be sized large enough to power the control panel, as well as a 15-Amp GFCI receptacle on the internal door, internal condensation heater (for unheated locations), a SCADA panel (5-amp load), and any other loads fed from the transformer that are specified in the project. Provide separate breakers for internal control power, courtesy lighting/GFCI receptacle, condensation heater, SCADA panel, and any 120V field devices such as flow meters or lighting that are to be fed from the control panel transformer.
- 5) Full-voltage starters can be of the IEC or NEMA type with either Molded-Case circuit breakers and overload blocks, or Motor Circuit Protectors. Overload trip must be reset manually.
- 6) VFD's shall be Danfoss VLT Aqua, and be controlled by discrete, hard-wired inputs and outputs; not over a network. Signals to the VFD include analog Speed Reference, digital Run-Command, and a digital signal to command a preset speed when operated in HOA Hand mode or by the Float Backup System.

Signals from the VFD include analog Speed Feedback, digital "Running" signal and a digital "Faulted" signal. If possible, the "Faulted" signal will originate from NC contacts of the VFD's internal Fault Relay and will be sent even if the VFD is powered off. A powered-up and healthy VFD will energize its Fault Relay to shut the Faulted signal off. "Running," "Faulted" and Speed Feedback signals will connect to PLC inputs.

- 7) The PLC, its digital and analog inputs, Operator Interface panel, and certain other devices shall be powered by a nominal 24VDC, battery-backed power supply. Provide a combination trickle-charger/power supply that seamlessly fails over to battery power upon loss of utility power. Voltage output of this type of supply is typically 27.5 Volts. The power supply must be able to provide typical voltage to the control circuit even while charging fully-discharged batteries. Provide a Meanwell DRC-180B or equivalent. Include (2) 12V, 12AH gel-cell batteries. If mounted on the back panel, provide a drip pan beneath the batteries to isolate acid leaks.

- 8) Terminal blocks shall be provided for pump thermostats and seal leak probes. The control panel shall be equipped with devices to receive and process these signals. Seal Leak detection shall be by means of standard Seal Leak Detection modules that apply low voltage to the pump's seal leak probes. Obsolete methods, such as using the seal leak probes to complete the neutral path for 120V relay coils, shall not be used. Over-Temperature and Seal Leak conditions shall prohibit a pump from running. They shall connect to PLC inputs and reset automatically.
- 9) Primary level control shall be by means of a submersible pressure transducer providing 4-20 mA to a PLC input. Provide a passive Intrinsically-Safe Zener barrier for the transducer.
- 10) Secondary level control shall be accomplished by float-backup circuitry in the pump control panel. It shall be able to control the pumps even if the PLC becomes inoperable. Floats shall connect to Intrinsically-Safe relays in the control panel. Float backup circuitry shall not contain any type of PLC or smart relay. It shall be composed of relays. There shall be Low-Level Alarm, Pumps-Off, Lead-Start, Lag-Start, and High-Level Alarm floats. Floats, except for the Low-Level Alarm float, will be positioned above the normal operating levels in the wet well. The Low-Level Alarm float will be located near the bottom of the wet well.

Float Backup circuitry will call Pump 1 when the Lead-Start float trips. If the level rises to the Lag-Start float, Pump 2 will be called. Pump 2 will be called by a timing relay to prevent simultaneous startup after power failure. Pumps will run until the Pumps-Off or Low-Level Alarm floats drop. A pump must be set to HOA Auto Mode for the Float Backup System to control it. When the Float Backup circuitry calls a pump, it will send a signal to a PLC input to signify Backup Mode Active. For VFD systems, when Float Backup mode is active, it shall send a digital signal to the VFD's to command a preset speed.

The Low-Level Alarm float will prohibit all HOA Auto Mode pump operation but will not prohibit operation in HOA Hand Mode. Low-Level Alarm and High-Level Alarm signals shall connect to PLC inputs.

Floats shall be composed of polypropylene, internally weighted, with form C (SPDT) contacts rated for minimum current of 1 mA @ 4V. Wire size AWG 18 minimum. Provide Primax Muni or equivalent. Provide a stainless-steel hanger having hooks for each float and the pressure transducer. Provide Kellums-style stainless steel cord grips for each float and transducer.

- 11) The PLC shall be Allen-Bradley Micrologix 1400, 1766-L32BXB (24V Power, 24V Inputs, combination transistor and relay outputs, no on-board analog, maximum 7 expansion modules). PLC and HMI programming to be done by the City's SCADA provider.

Digital inputs shall be 24VDC. Analog inputs and outputs shall connect to expansion modules, such as 1762-IF4 and 1762-OF4. The use of PLC base unit analog inputs and outputs, found on PLC model 1766-L32BXBA, shall be permitted only when I/O capacity is exhausted. In that case, do not use on-board analog I/O for signals that are likely to be exposed to lightning, such as wetwell level sensors. On-board analog voltage inputs may be converted to milliamp inputs by the addition of load resistors. On-board analog voltage outputs are not suited as milliamp outputs, since they are limited by design to 10 mA max.

Install enough I/O modules to accommodate the I/O required for the project and for any I/O specified for future upgrades. Do not install spare modules for unallocated or unspecified I/O points. (They will eventually fail and needlessly fault the PLC).

12) PLC digital inputs shall include:

- Utility Power OK (Originating from a phase monitor when applicable, or from a relay powered by 120V control power if there is no line power in the panel)

For each wetwell:

- High Level Float
- Low Level Float
- Float Backup System active

For each pump:

- HOA Auto mode
- Running
- Overload/VFD Fault
- Seal Leak
- Motor Temperature OK

For projects that include standby generators:

- ATS Emergency Position
- Generator Running
- Generator Failure
- Generator Low-Fuel

13) PLC analog inputs shall include:

- Wetwell Level
- Effluent Flow
- Pump Speed (From VFD)
- Pump Amperage (From VFD or motor current transducers)

14) Devices to be located on the inner door:

- Operator Interface panel
- GFCI Receptacle

For each pump:

- HOA Switch – with Auto Mode signal connected to a PLC input
- Pump Running light
- Run-Hour meter

16) Connection to the C-More HMI may be through the PLC's Ethernet port or through its 8-pin circular DIN connector. If Ethernet communication is used, provide an Ethernet switch. The HMI shall be C-More CM5-T10W.

17) There shall be an LED or Xenon alarm light mounted on top of the control panel, visible from all directions. It shall be sufficiently bright to be clearly visible and noticeable in daylight. The light shall flash and be covered with a red glass or plastic cover. The light will illuminate when any major pump fault or high-level alarm activates.

18) The PLC shall be programmed by the City's SCADA provider to accomplish the following tasks:

- Scale analog signals such as Level, Flow and Amperage to engineering units for control and display on the HMI and transmission to the SCADA system.
 - Control the pumps in Lead/Lag pump-down fashion. If pumps are controlled by VFD's, include the option for constant-level PID control. Provide a soft Auto/Manual mode to be set via the HMI or SCADA. In soft Manual mode, pumps may be controlled remotely, via HMI or SCADA.
 - Rotate the pump Lead/Lag status for even pump wear. Lead status shall be forfeited upon a major pump fault or when not in Auto mode. Lead status shall alternate at the end of a pumping cycle. For constant-level control, Lead status shall be forced to swap after 24 hours. Provide a Manual Alternation mode to allow a selected pump to retain Lead status indefinitely.
 - Totalize pump run-hours.
 - Totalize effluent flow for Today, Yesterday, This Month, Last Month.
 - Detect alarm conditions for the purpose of control and for display on the HMI and SCADA. Alarms to include high & low level, power failure, ATS emergency position, generator running, and all pump faults: overload, seal failure, over-temperature, run-failure, VFD fault. Alarms shall be self-resetting.
 - Assemble data into groups of contiguous registers for transmission to SCADA.
- 19) In order to assign warranty responsibility to a single party, the pump manufacturer must certify in writing that it accepts the Pump Control System as suitable for its pumping equipment.

H) SCADA Telemetry

- 1) The Contractor shall engage the services of the City's SCADA provider to program the pump-control panel PLC and HMI, and to provide radiotelemetry equipment and configuration for communication to the City's SCADA system. The SCADA provider is Teknon Controls, Inc. (tom@tekoncontrols.com, 502 639-2561).
- 2) SCADA telemetry is accomplished by licensed UHF serial radios operating at 465.075 MHz (transmit) and 460.075 MHz (receive). The repeater is located at the Jeffersonville Wastewater North Treatment Plant.
- 3) There shall be a SCADA telemetry panel located near the pump-control panel, equipped with a GE Orbit ECR radio or compatible equivalent, capable of 5 watts transmit power, a lightning arrestor, a 24VDC, battery-backed power supply, a thermostatically-controlled condensation heater (for unheated spaces), and circuit breakers, terminal blocks, wire duct etc. as necessary. The panel shall be 24" x 24" x 12", NEMA 4X stainless steel for outside locations; NEMA 12 for inside locations. The panel door shall be padlockable.
- 4) Electrical connections to the SCADA telemetry panel:
 - 120VAC from the Pump-Control panel or load center.

- CAT5 Cable connected from the Pump-Control panel PLC's DB9 RS-232 port through an RJ45-DB9 adapter to the radio's RJ45 RS-232 port.
 - LMR400 Coaxial cable from the lightning arrester that protrudes from the bottom of the panel to the antenna.
 - There is no need to connect separate alarm signals to the SCADA cabinet. All status and alarm information resides in the PLC, and this information is sent via the CAT5 cable to the radio.
- 5) The City's SCADA provider shall verify the radio path to ensure adequate radio signal strength, provide the SCADA telemetry panel, the antenna and transmission line, procure FCC licensing, install the antenna and transmission line, and configure the City's SCADA server to receive and display the data. The antenna shall be Pulse-Larsen YA3450WN. The Contractor shall provide and install the antenna mast, typically a 10-foot length of 1-1/4" rigid conduit.
 - 6) If the SCADA provider finds that UHF radio communication between the pump station and the repeater is too weak, SCADA communication will be by cellular modem.

3.4 Materials – Force Main

A) Force Main

1) PVC Pipe

- a) PVC pipe must meet ANSI/AWWA C900 for 4-inch pipe through 60-inch pipe or ASTM D 2241. The design and manufacture of pipe must meet minimum requirements of a working pressure of 150 pounds per square inch plus 100 pounds per square inch surge and a safety factor of 2 at the depth of cover indicated on the plans. Wall thickness of pipe and integral bell must have a minimum dimension ratio of 21 (SDR or DR).
- b) PVC compounds shall equal or exceed ASTM D 1784 class 12454-B.
- c) Push-on joints with bell integrally cast into pipe shall be provided. The joint must comply with ASTM D 3139 and the physical requirements of Uni-Bell PVC Pipe Association' UNI-B-1 "Recommended Specifications for Thermoplastic Pipe Joints, Pressure and Non-Pressure Applications."
- d) Elastomeric gaskets, as provided in ASTM F 477 shall be used. Gaskets must meet all applicable requirements of ANSI A-21.11.
- e) PVC fittings for pipe smaller than 4 inches must be fabricated in such a manner as will provide strength and water tightness at least equal to the class and material of the adjacent main line pipe to which they are joined. Pipe 4 inches and larger must utilize ductile iron fittings.

2) HDPE Pipe

- a) Materials used for the manufacture of HDPE pipe and fittings must be extra high molecular weight, high density HDPE 3408 polyethylene resin. The pipe must be extruded from virgin resin meeting the specifications of ASTM D 3350 with a minimum cell classification of

HDPE 345434C. Fittings must be manufactured from the same resin type and cell classification as the pipe itself.

- b) The pipe and fittings must contain no recycled compound except that generated in the manufacturer's own plant from resin of the same raw material.
- c) The material must be listed by PPI ("Plastics Pipe Institute", a division of the Society of the Plastics Industry) in its pipe grade registry technical report (TR).
- d) A 73° Fahrenheit hydrostatic design basis of 1,600 pounds per square inch and a 140° Fahrenheit hydrostatic design basis of 800 pounds per square inch. e) The manufacturer must conform to ISO 9001.
- e) Pipe supplied must have a nominal iron pipe size outside diameter.
- f) Pipe and fittings having a diameter of 3 inches and larger must be made to the dimensions and tolerances specified in ASTM F 714 with a cell class of PE 345434C. Pipe and fittings with diameters less than 3 inches must be made to the dimensions and tolerances set forth in ASTM D 3035 with a cell class of PE 3408.
- g) Fittings must be manufactured in accordance with ASTM D 3261. Fittings must be manufactured by injection molding, a combination of extrusion and machining, or fabricated from PE pipe conforming to this specification.
- h) Fittings must be fully pressure rated and provide a working pressure equal to that of the adjacent pipe with an included 2-to-1 safety factor.
- i) The pipe and fittings must be homogeneous throughout and free of visible cracks, holes, voids, foreign inclusions, or other defects that may affect the wall integrity.
- j) The pipe and fittings for horizontal directional drilling must be a minimum DR of 9. Pipe and fittings used in open cut installations must be a minimum of DR 11. l)
- k) Joints
 - i) The butt fusion process should be used to join sections of HDPE pipe into continuous lengths above ground at the job site. The joining method must be by the heat fusion method and must be performed in strict accordance with the pipe manufacturer's recommendations. The heat fusion equipment used in the joining procedures must be capable of meeting all conditions recommended by the pipe manufacturer, including, but not limited to, temperature requirements, alignment and interracial fusion pressure.
 - ii) Properly executed electrofusion fittings may be used.

Socket fusion, extrusion welding, hot gas welding or threading and gluing of HDPE pipe will not be accepted.
 - iii) Mechanical joint adapters are required to mechanically connect HDPE pipe to main line valves 3 inches or larger. Two-inch valves and smaller must be connected by compression fittings.
 - iv) Refer to the manufacturer's recommendations for proper installation procedures.
 - v) Fused segments of pipe must be handled so as to avoid damage to the pipe.

- vi) Chains or cable type chokers must be avoided when lifting fused sections of pipe. Nylon slings are preferred. Spreader bars are recommended when lifting long fused sections.

3) Ductile Iron (DI) Pipe

- a) Ductile iron pipe must meet ASTM A746 or ANSI/AWWA C151/A21.51 with exterior asphaltic coating (for buried service) and interior special asphaltic lining (for buried and exposed service) conforming to all appropriate requirements for seal coat described in ANSI/AWWA C104/A21.4. Thickness design of DI pipe must be in accordance with ANSI/AWWA C150/A21.50.
- b) Provide thickness class as indicated on Construction Plans, or, as a minimum:
 - i.) Four (4) inch diameter – Class 51, minimum.
 - ii.) Six (6) to twenty (20) inch diameter – Class 50 minimum
- c) All DI pipe, fittings and restrained joints must be wrapped with a minimum of eight (8) mil polyethylene conforming to ANSI/AWWA C105/A21.5 prior to being backfilled. Polyethylene adhesive tape is required for closure of all open edges against pipe or fitting.
- d) All exposed DI pipe, including pipe with pump station/force main manholes, must be painted with three (3) coats of Tnemec Company, Inc. two (2) part epoxy paint Hi- Build Epoxoilne Series 66 (66-INO1) as supplied by JD Petro o Franklin, IN.
 - i.) All surfaces must be cleaned as directed by paint manufacturer and Engineer but at a minimum the exposed wet well piping must receive SSPC. The Society for Protective Coatings (“SSPC”) SSPC-SP5/NACE 1 white metal blast cleaning and valve vault piping must receive SSPC-SP3 power tool cleaning.
 - ii.) Thinning of factory mixed paint will not be permitted.
- e) Joints on DI pipe must be the integral bell type push-on joint meeting ANSI/AWWA C111/A21.11 mechanical joint (“MJ”) meeting ANSI/AWWA C111/A21.15 or flanged joint meeting ANSI/AWWA C110/A21.10, C153/A21.53 or C115/A21.15. Buried accessories for mechanical and flanged joints must be alloy steel “T” head bolts (for MJ) or heavy hex head/hex head bolts (for flanged) and heavy hex nuts of coarse thread series class 2A external and class 2B internal per ASME/ANSI B1.1. Accessories for flanged joints in exposed services must be stainless steel meeting the thread requirements of coarse thread series class 2B.
- f) Provide flange joints for all exposed piping.
- g) Provide mechanical sleeve type coupling where specified or indicated.
- h) Provide anchored couplings where indicated or where restraint is required to withstand specified operating or hydrostatic test pressure.

B) Air Release and Cleanout Manholes and Equipment

- 1) Precast concrete manholes shall conform to ASTM C 478 with rubber type gaskets equal to ASTM C 443 and a minimum inside diameter of 48 inches. Monolithic cast-in- place manholes shall only be used with the prior written approval of the City. The base and first riser section of the precast concrete manhole shall be integrally cast as one unit. Precast concrete cones shall be of

the eccentric cone type. No “see through” lift holes shall be allowed on precast concrete manholes 48 inches in diameter or less. In addition to the rubber type gaskets, all joints shall receive a 1/2-inch diameter non-asphaltic mastic (Kent-Seal or as approved by the City), conforming to ASHTO M198 and federal specifications SS-S-210A. Sewer connection to manhole shall be Kor-N- Seal, A-Lok, Dura-Seal or as approved by the City.

- 2) Where one solid riser or barrel section cannot be used, final adjustment in elevation of the frame and cover shall be accomplished by the use of a 4-inch minimum thickness adjusting ring to a maximum combined thickness of 12 inches. Brick or block shall not be used in the construction of a manhole or to adjust the elevation of the frame and cover. Non-hardening butyl rubber sealant shall be installed between cone, riser rings, and casting. Sealant shall meet or exceed ASTM 0990-94.
- 3) Manhole steps are prohibited.
- 4) Joint seal system for the setting of a manhole casting shall be Infi-Shield Uniband or equivalent. The manufactured joint seal shall be made of a high-quality EPDM rubber with a minimum thickness of 60 millimeters that meets or exceeds ASTM C 923. The joint shall have 2-inch wide mastic strips on the top and bottom of the roll. The mastic shall be non-hardening butyl rubber sealant that meets or exceeds ASTM 0990-94. The seal shall be designed to prevent leakage of water into the manhole.
- 5) Manhole covers shall be Type "A" cast iron ring and cover and must conform to ASTM A48. All sanitary manholes that lay in or along a stream, swale, or open storm channel shall have locking or bolt down lids with an inside seal between the lid and casting. Manhole lids shall be stamped "CITY OF JEFFERSONVILLE SANITARY SEWER." Casting shall be East Jordan Ironworks 1045 casting and 1022 lid, Neenah R1642, or equivalent.
- 6) Minimum manhole diameter shall be 48-inches, for force main systems with force main sizes 4-inch diameter to 24-inch diameter.
- 7) All piping inside force main air release and cleanout structures shall be ductile iron pipe and extended ten feet outside of each structure, in accordance with the ductile iron pipe section of these specifications.
- 8) Air/vacuum release valves shall be A.R.I. Model D-025, or equal.

C) Bedding and Backfill

- 1) Contractor shall comply with Bedding and Backfill requirements as required by the City of Jeffersonville Construction Standard Details Sheets.

3.5 Execution

A) Pre-Construction Conference

- 1) Before the start of any construction on the project site, a conference must be scheduled and completed with the Department and the Department’s Inspector.

B) Permits

- 1) The Contractor or Property Owner must obtain sewer permits at one time. The sewer permit must be obtained before connection can be made.

C) Utility Location

- 1) The Contractor is responsible for determining the location of existing utilities 24 hours prior to any construction or excavating.
- 2) Two-inch wide sewer detection tape shall be laid 12 inches above top of pipe including mainline and laterals prior to sewer backfilling.

D) Submersible Pump Station

- 1) The pump station shall be provided with an access drive to the nearest public right-of-way.
- 2) Access drive shall include paved area around the pump station adequate for utility trucks to turn around, remove pumps and service equipment.
- 3) The control panels and generator receptacle must be located within ten (10) feet of the pump station drive so that a portable generator can be readily connected to the generator receptacle.
- 4) The wet well, valve vault, and meter pit shall be enclosed at grade level with a reinforced concrete pad, rectangular in shape and extending a minimum of 1'-0" from the chambers' outside dimensions.
- 5) "Live" yard hydrant shall be installed inside fence area (if possible) and close to fence, to provide water service for pump station maintenance purposes, per City of Jeffersonville Standard Details. Contractor shall coordinate with the appropriate water company and obtain applicable local and state water permits before installing such facilities. Contractor shall provide backflow preventer, installation, testing, flushing, and disinfection of water main and hydrant system, in accordance with Water Company requirements.

E) Air Release and Cleanout Structures and Equipment

- 1) Force Main Air Release and Cleanout Structures shall be placed on a minimum 6 inches of No.8 crushed stone that has been mechanically compacted. Where unstable or poor soil conditions exist, additional No. 2 crushed stone or Class B concrete shall be placed to form a stable base. The remainder of the manhole shall be backfilled using No. 53 or No.8 stone. Stone shall be placed in 6-inch lifts and mechanically compacted to 95 percent maximum dry density as determined by ASTM D 698.
- 2) Joint seal system (Kent-Seal or as approved by the City) shall be installed using the Manufacturers written instructions. The top of the manhole casting and cone section shall be joint-sealed with inspection prior to backfilling.
- 3) Connections to all manholes, new or existing, shall be core drilled and booted. These taps shall be cored into the manhole between the spring line of the sewer or no more than 24 inches above the flow line. Manhole connections shall not protrude past the interior of the wall of the manhole.
- 4) All sanitary manholes shall be vacuum tested with castings per ASTM C 1244 93 following full installation. All sanitary manhole sections shall be vacuum tested in the shop prior to shipment.

F) Backfill

- 1) Bedding and backfill dimensions shall have a minimum trench width as designated on the standard construction details.

G) Safety and Spills

- 1) CONTRACTORS ARE SOLELY RESPONSIBLE FOR ALL SEWAGE SPILLS that occur as a result of their work. The Contractor must have an action plan to anticipate problems connecting to existing sewers and pumping sewage around a work site.
- 2) CONTRACTORS ARE RESPONSIBLE FOR SAFETY AT THE JOB SITE. They shall make provisions for a safe working environment for their own crews, as well as City personnel and inspectors. The project site shall be in compliance with all OSHA safety regulations, including but not limited to construction trench safety and confined safety entry regulations.
- 3) Should unknown active utilities be damaged during excavation work, work must be stopped immediately. Do not proceed with work until decision has been reached regarding repair, removal, or relocation of utilities. The Contractor must give notice to the appropriate utility.

H) Testing

1) General Testing Requirements

- a) All testing must be conducted at the Contractor's expense in the presence of the City.
- b) Notification must be provided at least five (5) days prior to any testing.
- c) All testing (except manhole vacuum testing) must be conducted after the final backfill has been in place and is undisturbed for at least thirty (30) days and after all other utilities have been installed. All concrete thrust blocks must have been in place for a period of at least ten (10) days prior to testing.
- d) At the Department's discretion, testing may be delayed or additional testing may be required, based upon weather conditions (inadequate precipitation to allow for adequate settlement, etc.) Also, testing may be delayed or additional testing may be required due to the installation of site improvements (including but not limited to fencing, signage, landscaping, site lighting and other sub surface improvements).
- e) If the Owner requires sanitary sewer service prior to final testing, a preliminary test may be performed, however, the Owner must provide, in writing, a guarantee that all cleaning and testing will be performed per the construction plans and the Department's then current standards, specifications and details.

2) Force Main Testing

- a) Hydrostatic pressure tests must be performed on all force mains.
- b) The hydrostatic pressure test must conform to ANSI/AWWA C600 and C605 procedures except as modified by these specifications.
- c) Conduct test at pressure of at least 100 pounds per square inch or 1.5 times the operating pressure, whichever is greater.
- d) Maintain pressure for a minimum of 2 consecutive hours.
- e) Test pressure must not vary by more than 5 +/- pounds per square inch.

- f) During filling of the pipe and before the application of the specified test pressure, all air must be expelled from the force main by means of the air/vacuum release valves and, if necessary by additional taps at points of highest elevation. After the test is finished, the taps must be tightly plugged, unless otherwise specified.
 - g) Limit fill rate of force main to available venting capacity. Fill rate must be regulated to limit velocity in force main when flowing full to not more than 1 foot per second.
 - h) Test separately in segments between isolation valves, between an isolation valve and a test plug, or between test plugs.
 - i) Contractor shall furnish and install test plugs, including all anchors, braces and other temporary or permanent devices to withstand hydrostatic pressure on plugs.
 - j) Contractor is responsible for any damages caused by failure of the sanitary sewer facilities during testing of the project.
 - k) Contractor shall refit and replace all pipes not meeting the leakage or pressure requirements.
 - l) Contractor shall repair all visible leaks regardless of the amount of leakage.
 - m) Contractor shall repeat hydrostatic pressure test as necessary:
 - After location of leaks and repair or replacements of defective joints, pipe or fittings.
 - Until satisfactory test results are obtained.
 - Open all air/vacuum release valves and verify proper operation.
 - n) The system will not be considered complete until all leaks have been repaired and all tests have been passed to the satisfaction of the Wastewater Department.
- 3) Manhole Testing
- a) All air/vacuum release, clean-out and flow monitoring/metering manholes must be vacuum tested after installation, repair or modification.
 - b) Installation and operation of vacuum equipment and indicating devices must be in accordance with manufacturer's recommendations and performance specifications that have been provided by the manufacturer and accepted by the City.
 - c) All manholes shall be negative air pressure (vacuum) testing methods in accordance with ASTM C1244-93. These tests shall be performed by the Contractor and observed and confirmed by a representative of the Department.
 - d) Stub outs, manhole boots and pipe plugs must be secured to prevent movement while the vacuum is drawn.
 - e) Procedures: With the vacuum tester set in place:
 - i.) Inflate the compression band to 40 psi to affect a seal between the vacuum base and the structure.
 - ii.) Connect the vacuum pump to the outlet port with the valve open.
 - iii.) Draw a vacuum 10" of Hg. and close the valve.

- f) Acceptance standards for leakage will be established from the elapsed time for a negative pressure change from ten (10) inches to nine (9) inches of mercury. The maximum allowable leakage rate for a four-foot diameter manhole must be in accordance with Table 7 below:

TABLE 7			
Manhole Depth	Minimum Elapsed time for a Pressure Change of 1 Inch HG		
	Four (4) foot manhole	Five (5) foot Manhole	Six (6) foot Manhole
10 feet or less	60 seconds	75 seconds	90 seconds
>10 feet <15 feet	75 seconds	90 seconds	105 Seconds
>15 feet <25 feet	90 seconds	105 seconds	120 seconds

For all manholes deeper than 25 feet, the Department will determine the applicable minimum elapsed time.

- g) Retest:
- i.) If the manhole fails the test, necessary repairs must be made and the vacuum test and repairs must be repeated until the manhole passes the test.
 - ii.) If manhole joint seals are pulled out during the vacuum test, the manhole must be disassembled and the joints replaced.
- h) Visual:
- i.) Manholes will be subject to visual inspection with all visual leaks being repaired.
- i) Testing Form:
- i.) Contractor must submit the results of the vacuum test with the following information:
 - Project Name
 - Contractor
 - Date of Test
 - Manhole ID number
 - Manhole Diameter
 - Manhole Depth
 - Test Duration (Seconds)
 - Pressure Drop (Inches of Mercury)
 - Pass/ Fail
 - Testing Operator's Signature
 - Engineer's Representative Signature

4) Pump Testing

- a) In order for the pump station/force main project to be approved and accepted by the City of Jeffersonville, upon completion of the project, the Developer shall be responsible for scheduling a pump station start-up test and inspection meeting with the Department, or other Department representatives, in attendance, along with Contractor, Design Engineer, and Pump Manufacturer's representative.

- b) The Developer shall be responsible for assuring that the pump station is running properly and in accordance with the project design. During the start-up test and inspection meeting, the following tests shall be run:
 - i.) The pump manufacturer's representative shall run a pump down test on all pumps and control panels and record the following test data (but not limited to the following test data), for submittal to the Jeffersonville City Engineer, for approval.
 - (a) Conduct pump down test on all pumps, to check that pumps are operating at the designed pump conditions [flow (gpm) at total dynamic head (TDH)]
 - (b) Check pressure gauge readings and hour meter readings during pump down test.
 - (c) Check breaker switches.
 - (d) Check hand-off-automatic switches
 - (e) Check amperage
 - (f) Check automatic operation on all pumps and check float- and pressure transducer/level sensor-sequencing with pumps.
 - (g) Check seal failure/heat sensor
 - (h) Check all control components, alarm lights, horn activation
 - (i) Check float settings and recheck float elevation
 - ii.) The valve supplier and the flow meter supplier shall run applicable tests on all valves/flow meter and record the following test data (but not limited to the following test data). Submittal to the Department for approval.
 - (a) Check if packing leaks
 - (b) Check valve opening and closing and flapper operating properly
 - (c) Check flow meter readings up against the pump down test results.
 - iii.) The Department's SCADA system designer shall run tests on the SCADA system and record the test data, for submittal to the Wastewater Department for approval.

4.0 Bore and Jack

4.1.1 General

- A. Under this section the CONTRACTOR shall be required to furnish all materials, equipment, labor and all other necessary items to install the Steel Casing and Carrier Pipe, where shown, in accordance with the subject plans, specifications and INDOT Rules and Regulations.

4.1.2 Execution – Casing Pipe

- A. The CONTRACTOR shall bore and jack the steel casing pipe where called for on plans. Casing pipe shall meet requirements of ASTM A501-682 Steel casing pipe. All joints in the casing shall be welded.
- B. Casing pipe shall have all welded joints through its' entire length to prevent leakage of any type.
- C. Steel casing pipe shall have a minimum yield strength of 35,000 psi.

4.1.3 Execution – Carrier Pipe

- A. The carrier pipe shall be as shown on plans and in accordance with the Jeffersonville Wastewater Department Construction standards for sanitary sewer materials or force main materials, whichever is applicable.
- B. After the pipe is placed inside the Steel Casing, the annular space at each end, between the inside wall of the casing and the outside wall of the pipe shall be sealed with concrete grout, end seals, and/or concrete bricks and grout 12 inches deep (back into the pipe) as to be watertight.
- C. The CONTRACTOR shall install the carrier pipe inside the casing which would protrude out each end.
- D. Stainless steel or wooden block spacers shall be used to align carrier pipe inside the casing if applicable.

4.1.4 Boring

- A. This method consists of pushing the pipe into the soil with a boring auger rotating within the pipe to remove the spoil.
- B. The front of the pipe shall be provided with mechanical arrangements or devices that will positively prevent the auger from leading the pipe so that there will be no unsupported excavation ahead of the pipe.
- C. The auger and cutting head arrangement shall be removable from within the pipe in the event an obstruction is encountered.

- D. The over-cut by the cutting head shall not exceed the outside diameter of the pipe by more than one half inch. If voids should develop or if the bored hole diameter is greater than the outside diameter of the pipe (plus coating) by more than approximately 1 inch, grouting or other methods shall be employed to fill such voids.
- E. The face of the cutting head shall be arranged to provide a reasonable obstruction to the free flow of soft or poor material.
- F. Plans and description of the arrangements to be used shall be submitted to the Engineer for review and no work shall proceed until such review is completed.
- G. If an obstruction is encountered, the operation shall be stopped and the CONTRACTOR shall contact the OWNER.
- H. There shall be at least 4.0 feet of cover over the casing pipe to any pavement.
- I. Pipe shall be bored to the grades shown on the plans.

4.1.5 Safety Requirements

- A. At all times when the work is being progressed, a Field Supervisor for the work with no less than twelve (12) months experience in the operation of the equipment being used shall be present. If boring equipment or similar machines are being used, the machine operation also shall have no less than twelve (12) months experience in the operation of the equipment being used.

4.1.6 Protection of Drainage Facilities

- A. If, in the course of construction, it may be necessary to block a ditch, pipe or other drainage facility, temporary pipes, ditches or other drainage facilities shall be installed to maintain adequate drainage. Upon completion of the work, the temporary facilities shall be removed and the permanent facilities restored.
- B. Soil erosion control methods shall be used to protect ditches and other drainage facilities during construction.

4.1.6 Cleanup and Seeding

- A. After installation of the pipe and casing is complete, all areas shall be cleaned of debris of any kind, smooth graded to drain and seeded. All debris shall be disposed of by the CONTRACTOR.

4.1.7 Bore Requirements

- A. All work shall not interfere with the ongoing daily operation.
- B. The work shall not alter the condition of any pavement or overlying property.
- C. Any damage or alterations to pavement or ground surface will be repaired by the CONTRACTOR.

5.0 LOW PRESSURE SEWER SYSTEMS (LPSS)

5.1 PURPOSE

- 4.1.1 This section establishes the minimum standards and technical design criteria for sanitary Low-Pressure Sewer Systems (LPSS) in the City of Jeffersonville service area for Capital Improvement and development projects. Hydraulic design presented herein represents acceptable procedures not necessarily to the exclusion of other sound and technically supported design procedures. Any departure from these design requirements should be brought to the attention of the City of Jeffersonville Wastewater Department before submission of plans for approval and should be justified and documented.

5.2 OVERVIEW

- 5.2.1 General Design - The overall design of LPSS consists of the determination of the following:
- A. The location of the horizontal alignment which most efficiently provides service to existing and potential users.
 - B. The vertical restrictions on establishing the LPSS alignment, including: minimum cover, elevations of other sewers in the system, conflicts with other underground facilities, and solid rock considerations.
 - C. The design flow generated by the existing and future users, which must be transported by the LPSS.
 - D. The pipe size, pipe material, and method of construction required.
 - E. The necessary appurtenances and special structures required.
- 5.2.2 LPSS Responsibility and Ownership
- 1) For private or Public Works LPSS projects, it is the intent of the City of Jeffersonville that all LPSS construction within the limits of the right-of-way be completed as part of the same project to be considered substantially complete. This includes the Private Service Connection (PSC) from the main line pressure pipe to the Uni-Lateral valve assembly at the right-of-way line. This is to avoid future damage to pavement or other improvements in the right-of-way from future service line connections to the main line LPSS pipe.
 - 2) Property owners (or developers) will be responsible after the City's acceptance of the LPSS for acquiring and installing the service lateral from the Uni-Lateral valve assembly, the grinder pump station, connecting their private sanitary line to the station, and, if applicable, properly abandoning their existing on-site treatment system.
 - 3) Following substantial completion of the LPSS, the City of Jeffersonville will own and be responsible for operation and maintenance of the following, notwithstanding any responsibilities required by applicable warranties:

- a. Main line LPSS sanitary pressure pipe within rights-of-way or easements.
 - b. Main line appurtenances such as air valve structures and clean outs/flushing connections.
- 4) Following substantial completion of the LPSS, the property owner receiving sanitary sewer service will own and be responsible for operation and maintenance of the following, notwithstanding any responsibilities required by applicable warranties:
- a. The PSC from the main line LPSS sanitary pressure pipe within rights-of-way or easements.
 - b. The Uni-Lateral stainless-steel curb stop/check valve assembly located at or near the right-of-way line where it meets their own property line.
 - c. The pressure and gravity service laterals located on their own property.
 - d. The grinder pump station and all associated panels.

5.3 GENERAL LOCATION CRITERIA

- 5.3.1 Since it is a pressurized system there is significant flexibility for LPSS horizontal and vertical location to determine the most cost-effective and environmentally sensitive alignment that best serves the needs of the entire tributary area. Additionally, it is imperative that all alternatives worthy of consideration receive maximum and equal consideration regarding environmental impact. The costs and acquisition time for easements can be significant; therefore, LPSS should be located within existing easements and rights-of-way whenever feasible and practical.
- 5.3.2 When selecting the LPSS alignment, consideration should be given to the following general location criteria:
- A. For protection of environmentally sensitive areas and constraints such as creeks, wetlands, trees, protected habitats, etc.
 - B. Existing utilities, railroads, highways, and overhead facilities.
 - C. Location of other existing and proposed sewerage and stormwater facilities.
 - D. Property values, easement needs and potential damage to the affected properties.
 - E. Existing and proposed high water elevations, including high water for appropriate design periods.
 - F. Anticipated extension of existing streets and the potential for the development of contiguous areas.
 - G. Continuity with adjacent design segments.

- H. Maintenance of traffic.
- I. Availability of materials.
- J. Foundation conditions.
- K. Construction cost.

5.3.3 The location of proposed LPSS should also comply with applicable portions of Indiana Administrative Code 327 IAC 3 Rule 6 “Technical Standards for Sanitary Collection Systems”.

5.4 HORIZONTAL ALIGNMENT CRITERIA

5.4.1 General

- A. Installation of LPSS using Horizontal Directional Drilling (HDD) is preferred to limit surface disruption. Even so, consideration regarding horizontal alignment should be given to impacts from open-cut excavations at pit locations and potential future repairs and service connections.
- B. LPSS shall be located in non-paved areas in existing easements or rights-of-way, or within a sanitary easement adjacent to the road right-of-way and shall be at least 10 feet from the water main. Air relief valve manholes shall be completely outside the pavement and not partially in the pavement, unless approved by the Sewer Board. The centerline of the manhole shall be a minimum distance of 3 feet from the edge of pavement, and a minimum distance of 5 feet inside sanitary sewer easement.

5.4.2 LPSS Located under Pavement (Subject to Approval by Sewer Board)

- A. Construction of LPSS under pavement will be subject to approval by the Sewer Board. If circumstances require the LPSS to be located under the roadway, the pipe shall be located in the traffic lane on the opposite side of the street and at least 10 feet away from the water main with the centerline of the LPSS to be a minimum of 5 feet from the edge of pavement. Every effort shall be made to place the entire air relief valve manhole frame and cover entirely within the pavement. In areas where this location will conflict with gas and water valves or other utilities, the LPSS location shall be adjusted to avoid these conflicts. Consideration of other factors, such as the width of the pavement, depth of rock, and possible conflict with other utilities, will still be required so the LPSS can be built without modification during construction.
- B. In areas where concrete pavement is encountered, consideration shall be given to placing the LPSS in a location whereby one edge of the pavement to be removed would coincide with existing construction joints, which are generally in the centerline of the streets. This procedure would require that only one side of the pavement would have to be sawed for removal. In areas where lots slope abruptly away from the street, consideration shall be given to locating the LPSS near the property line on the low side.

- 5.4.3 Stationing - All LPSS stations shall increase upstream. Every effort shall be made to begin the stationing of an LPSS with Station 0+00.00 at the downstream end. When an existing sewer is to be extended, the stationing should be continued from the end of the existing sewer whenever possible. The PI stations and deflection angles or interior angles shall be shown on the plans at all changes in alignment.
- 5.4.4 LPSS Line Designations - The designation of the first LPSS in a collection system shall be LINE "A". The next LPSS upstream contributing to LINE "A" shall be designated LINE "B", and the station of LINE "B" at this point shall be Station 0+00.00. This method shall continue throughout the collection system and subsequent LPSS pipe runs shall be assigned appropriate designations by ascending letters. Lines beyond LINE "Z" shall continue with double letter designations starting with LINE "AA", "AB", etc.

5.5 VERTICAL ALIGNMENT CRITERIA

5.5.1 LPSS Depths

- A. LPSS shall have a minimum cover of 4 feet in easements and a minimum cover of 5 feet in rights-of-way. Specific exceptions to these minimum requirements may be made with prior approval by the City of Jeffersonville Wastewater Department.
- B. Grinder Pump Station bottoms shall be set as needed for the station influent to receive the first-floor lateral invert by gravity. Excessive Grinder Pump Station depths to receive basement sanitary facilities by gravity will not be allowed without prior approval by the City of Jeffersonville Wastewater Department.
- C. In developed areas with on-site wastewater treatment receiving sanitary service via LPSS it is to be assumed that any existing sanitary facilities in basements are served by a private sump pump discharging up to the common lateral from the structure to the septic tank. Excessive Grinder Pump Station depths to receive basement sanitary facilities by gravity will not be allowed without prior approval by the City of Jeffersonville Wastewater Department.
- D. A minimum cover of 2 feet shall generally be maintained when crossing under existing streams, existing ditches, and existing or proposed channel improvements and storm sewers, provided the LPSS line is encased in concrete (or capped if approved by the City of Jeffersonville Wastewater Department).

5.5.2 LPSS Gradients - All LPSS gradients shall be referenced to the North American Vertical Datum of 1988. When connecting into or extending existing sewer facilities that were constructed using another datum, an elevation equation should be shown on the plans.

5.5.3 Flooding and Ponding Areas - Since the LPSS is a pressurized system the only open points in the system are at the Grinder Pump Stations. The tops of these stations should be kept a minimum of 2 feet above existing, proposed, or projected 100-year flood elevations whenever possible. If doing so would result in the top extending above the final grade around the station, then it shall be lowered so the top matches final grade and a watertight lid shall be used.

5.5.4 Minimum Water Main Clearances - The following minimum clearances between the LPSS and existing or proposed water mains shall be used in establishing the LPSS alignment:

- A. Horizontal Clearance - The horizontal clearance shall be 10 feet minimum per the Indiana Administrative Code 327 IAC 3-6-9 "Separation of collection systems from water mains and drinking water wells." Where this is not possible, the Design Engineer should reference 327 IAC 3-6-9 for exceptions. Note that since the LPSS is a pressurized system it is considered similar to sanitary force main piping.
- B. Vertical Clearance - The vertical clearance shall be at least 18 inches per the Indiana Administrative Code 327 IAC 3-6-9 "Separation of collection systems from water mains and drinking water wells." The LPSS pipe shall be located below the water main. Where this is not possible, the Design Engineer should reference 327 IAC 3-6-9 for exceptions. Note that since the LPSS is a pressurized system it is considered similar to sanitary force main piping.

5.6 LPSS HYDRAULIC DESIGN CRITERIA

5.6.1 General

- A. LPSS design is to be based on established estimates to determine how many grinder pump stations within a system will simultaneously operate upstream of any given stretch of sewer pipe. This information is used to determine the pipe diameter that meets the velocity and TDH criteria.
- B. The system should be designed to give the shortest runs and the fewest abrupt changes in direction. "Loops" in the system must be avoided as they lead to unpredictable and uneven distribution of flow.

5.6.2 Flow Characteristics

- A. All LPSS main pipe shall be sized to carry the design flow for each segment at a velocity between 2.0 fps and 5.0 fps. Maximum Total Design Head (TDH) shall be 185 feet.
- B. Design Pipe Roughness Coefficient (C) shall be 120 and 150 for HDPE.
- C. Typical residential flow per grinder pump is assumed to be 11 gpm.

5.6.3 Air Valves

- A. Air/vacuum valves, air release valves and combination air valves serve to prevent the concentration of air at high points within a system. This is accomplished by exhausting large quantities of air as the system is filled and also by releasing pockets of air as they accumulate while the system is in operation and under pressure. Air/vacuum valves and combination air valves also serve to prevent a potentially destructive vacuum from forming.
- B. Air relief valves for LPSS should be installed at the beginning of each downward leg in the system that exhibits a 25-foot or more drop. Air will accumulate in downhill

runs preceded by an uphill run. It is not generally required to provide air valves for LPSS at high points where there is less than a 25-foot drop as air suspended in the flow will typically be forced downstream in the smaller diameter pipes.

- C. Long ascending or descending lines or long horizontal runs require air and vacuum or dual-function valves placed at approximately 2,000-foot intervals.

- 5.6.4 Cleanout and Flushing Stations - Cleanout and flushing stations should be incorporated into the pipe layout. In general, cleanouts should be installed at the terminal end of each main, every 1,000 to 1,500 feet on straight runs of pipe, and whenever two or more mains come together and feed into another main

5.7 HYDRAULIC COMPUTATIONS

- 5.7.1 It is intended that all LPSS in the City of Jeffersonville be designed to use the E/One grinder pump stations and appurtenances. Therefore, hydraulic computations are to be completed with E/One's Design Assistant Software, latest version. Alternatively, hydraulic analysis can be completed by E/One. These resources are available at: www.eone.com/sewer-systems/design-center
- 5.7.2 Use of alternative computation methods may be submitted to the City along with full backup documentation and explanation for consideration as an equal.

5.8 LPSS PIPE

- 5.8.1 High Density Polyethylene (HDPE)
 - A. LPSS pipe shall be High Density Polyethylene (HDPE) suitable for installation using either Horizontal Direction Drilling (HDD) or open-cut methods.
 - B. Pipe shall comply with ASTM D 3035, Standard Specification for Polyethylene (PE) Plastic Pipe (DR-PR) Based on Controlled Outside Diameter for pipe diameters up to and including 3-inches, and ASTM F 714, Standard Specification for Polyethylene (PE) Plastic Pipe (DR-PR) Based on Outside Diameter for pipe sizes 4-inches and larger.
 - C. Materials used for the manufacture of HDPE pipe shall be extra high molecular weight, high density ethylene/hexane copolymer PE 4710 or PE 3608 polyethylene resin meeting the requirements of ASTM D 3350 with a minimum cell classification of PE445474C for PE 4710 and PE345464C for PE 3608 for products manufactured in accordance with ASTM D 3035. Pipe shall be minimum DR 11 sized in accordance with IPS.
 - D. All material shall have a hydrostatic design basis of 1,600 psi or more. The pipe shall contain no recycled compound except that generated in the manufacturer's own plant from resin of the same specification from the same raw material. All material shall be listed by the Plastic Pipe Industry in the name of the pipe manufacturer and shall be based on ASTM D 2837 and PPI TR-4 testing and validation for samples of the pipe manufacturer's production pipe. Pipe shall have a co-extruded green cover or extruded green stripes designating it as a wastewater pipeline.

- E. HDPE pipe shall be joined into continuous lengths on the job site above ground. The joining method shall be the butt fusion method and shall be performed in strict accordance with the pipe manufacturer's recommendations. Electrofusion shall not be used except as needed to connect adjacent directionally drilled sections which are to be connected in the trench bottom. Mechanical joint adapters are required to mechanically connect the HDPE pipe to different pipe materials. Joint restraint to prevent axial separation shall be incorporated into the design of the sleeve or coupling used to connect HDPE pipe plain ends. Internal pipe wall stiffeners must be used when restraining HDPE. The restrained coupling system shall be Series 4800 manufactured by EBAA Iron, Inc. or an approved equal.
 - F. Fittings shall be the same HDPE material as the pipe. HDPE fittings shall be manufactured in accordance with ASTM D 3261 by injection molding, a combination of extrusion and machining, or fabricated from HDPE pipe conforming to this Specification. Fittings shall be fully pressure rated and provide a working pressure equal to the adjacent pipe with an included two to one safety factor. Joints between plain end pipes and fittings shall be made by butt fusion using procedures that are in accordance with ASTM F2620 by a person who is a manufacturer's certified thermojoiner.
 - G. During the extrusion production, the HDPE pipe shall be continuously marked per ASTM and AWWA with durable printing with, at a minimum, the following: nominal pipe size, dimension ratio, pressure rating, trade name, material classification, certification bases, and date.
 - H. In addition to the holding, storage, and color requirements in these specifications, when moving fused sections of pipe, chains or cable type chokers shall be avoided, nylon slings are preferred. Care must be exercised to avoid cutting or gouging the pipe.
 - I. Pipe possessing the following defects may be rejected for installation: variation from straight centerline; elliptical shape; illegible markings as required herein; deep or excessive gouges or scratches of the pipe wall; fractures, punctures, or cracks passing through the pipe wall; damaged ends where such damage would prevent making a satisfactory joint.
- 5.8.2 Minimum Diameter - The minimum allowable nominal inside diameter for LPSS pipe, other than property service connections, shall be 1-1/2 inches. All property service connections shall have a minimum nominal inside diameter of 1-1/4 inches; commercial or industrial connections shall be individually considered with the minimum nominal size being 1-1/4 inches.
- 5.8.3 Tracer Wire
- A. Tracer wires shall be installed along the LPSS main line and service line pipe, fastened securely to the pipe at five (5) foot intervals, and terminating above ground with the lead taped around each structure. The wire shall be brought up to the ground level every four hundred (400) feet through a vinyl coated aluminum riser pipe with cap and/or at all line valve boxes. The wires shall be connected using DBR Direct Burial

Splice Kit manufactured by 3M Electrical Products Division, Austin, TX or approved equal. The riser pipe and cap shall not be placed in areas subject to vehicular traffic. The tracer wire shall be capable of, and demonstrated to have, continuous transmission of tracing signal along the full length of the installed pipe. Wire ends shall be accessible at structures and risers and secured so they are in a visible location that can be connected to without completing confined space entry.

- B. If any appurtenant structure, such as an air release valve, is required as part of the low-pressure sewer installation, the wire shall be cut with each end entering the structure under the casting frame.
- C. Tracer wire shall be Copperhead Direct Burial #12 AWG Solid, steel core hard drawn extra high strength horizontal directional drill tracer wire, 1150# average tensile break load, 45 mil high molecular weight-high density green colored polyethylene jacket complying with ASTM D-1248, 30-volt rating or approved equal.

5.8.4 Hydrostatic Leakage Testing for LPSS - The hydrostatic leak test shall be done in accordance with AWWA standards based on the installed low-pressure sewer material, in accordance with ASTM E 1003, and as follows:

- A. The hydrostatic test may be done immediately after final backfill is placed and the air and/or vacuum release valves are installed.
- B. All leakage testing must be performed in the presence of a representative of the City of Jeffersonville Wastewater Department, and will provide a stopwatch, recording forms and calculations to demonstrate if the test passed or failed.
- C. When conducting any leakage test, the Contractor shall provide all meters, weirs, gages, water, equipment and personnel necessary to perform the test as specified. At a minimum, the following shall be provided:
 - a. Hydrostatic Test Pump (jockey pump).
 - b. Continuous monitoring pressure gage having a range of 0 – 150 psi graduated in 1 psi increments. The gauge shall be no less than four (4) inches in diameter.
 - c. Pipe plugs and/or caps. The plugs/caps shall be equipped with a minimum of two (2) openings for filling/draining the low-pressure sewer and for bleeding air from the line.
 - d. Calibrated/graduated container to measure the quantity of water required to be added during the hydrostatic test to maintain the test pressure.
- D. The procedures for the hydrostatic test are as follows:
 - a. Close isolation valves on the Uni-Lateral assembly. Redundant check valves on station laterals and anti-siphon/check valve assemblies on grinder pump cores should not be used as system isolation valves during line tests.
 - b. After the low-pressure sewer has been backfilled to final grade, securely plug

and/or bulkhead the ends being tested. Thrust blocking restraints shall be installed at each bulkhead in accordance with the bulkhead manufacturer's requirements.

- c. All air and/or vacuum release valves shall be installed and in normal (open) in-service position during the test.
- d. The low-pressure sewer shall be slowly pressurized with water to 1.5 times the working pressure, or 100 psi, whichever is greater. Trapped air shall be expelled through high point bleed off valves as the low-pressure sewer is being filled. When the pressure has been reached, the test pump shall be shut off. After the low-pressure sewer has been pressurized, measure the pressure drop for two (2) hours.
- e. If no pressure drop occurs within the two (2) hour test time, the low-pressure sewer shall have passed the test.
- f. If a pressure drop occurs within the two (2) hour test time, the low-pressure sewer shall have failed the test. The Contractor shall repair or replace all defective materials or Workmanship and conduct additional leakage tests necessary to demonstrate that the repaired section meets the leakage requirements, at no additional cost to the City of Jeffersonville. If requested by the City of Jeffersonville the Contractor shall submit in writing a method of repair which must be approved by the City of Jeffersonville before repair can begin.

5.9 GRINDER PUMP STATION

5.9.1 General

- A. Each unit shall be a complete factory-built and tested Wetwell/Drywell Grinder Pump Station consisting of grinder pump(s) suitably mounted in a basin constructed of high density polyethylene (HDPE) for simplex stations and HDPE or Fiberglass Reinforced Polyester Resin for duplex stations with dimensions and capacities as required in the Contract Drawings, NEMA 6P electrical quick disconnect (EQD), pump removal system, stainless steel discharge assembly/shut-off valve, and anti-siphon valve/check valve, each assembled in the basin, plus external electrical and alarm panel and all necessary internal wiring and controls.
- B. Component type grinder pump systems that require field assembly will not be acceptable. For ease of serviceability, all pump, motor/grinder units shall be of like type and horsepower throughout the system, unless otherwise specified herein. Grinder pump stations, complete with all appurtenances, form an integral system, and as such, all stations shall be supplied by a single grinder pump station manufacturer.
- C. All maintenance tasks for the grinder pump station shall be possible without entry into the grinder pump station, as per OSHA 1910.146 Permit-Required Confined Space.
- D. The grinder pump station shall have a cartridge type, easily removable core assembly

consisting of pump, motor, grinder, all motor controls, check valve, anti-siphon valve, level controls, electrical quick disconnect and wiring. The core unit shall be installed in the basin by the manufacturer. Field assembly of the pump and controls into the basin is not acceptable because of potential workmanship issues and increased installation time. The core unit shall seal to the tank deck with a stainless-steel latch assembly. The latch assembly must be actuated utilizing a single quick release mechanism requiring no more than a half turn of a wrench. The watertight integrity of each core unit shall be established by a 100 percent factory test at a minimum of 5 PSIG.

- E. The grinder pump core, including level sensor assembly, shall have two lifting hooks complete with lift-out harness connected to its top housing to facilitate easy core removal when necessary. The level sensor assembly must be easily removed from the pump assembly for service or replacement. All mechanical and electrical connections must provide easy disconnect capability for core unit removal and installation. Each EQD half must include a water-tight cover to protect the internal electrical pins while the EQD is unplugged. A pump push-to-run feature will be provided for field trouble shooting. The push-to-run feature must operate the pump even if the level sensor assembly has been removed from the pump assembly. All motor control components shall be mounted on a readily replaceable bracket for ease of field service.
- F. The equipment specified herein shall be a product of a company experienced in the design and manufacture of grinder pumps for specific use in low pressure sewage systems. The company shall submit detailed installation and user instructions for its product, submit evidence of an established service program including complete parts and service manuals, and be responsible for maintaining a continuing inventory of grinder pump replacement parts. The manufacturer shall provide, upon request, a reference and contact list from ten of its largest contiguous grinder pump installations of the type of grinder pumps described within this specification.
- G. Unless otherwise specified, all grinder pump stations shall be semi-positive displacement type Model DH071, as manufactured by Environment One.

5.9.2 Alternate Equipment

- A. The City of Jeffersonville Wastewater Department may, at their sole discretion, consider an alternative grinder pump station and manufacturer for pre-approval as an equal.
- B. If the contractor or another supplier proposes an alternate to the specified manufacturer, it is recognized that it will be difficult to conform to certain details of this Specification due to different manufacturing techniques or grinder pump station designs. If proposing an Alternate, the contractor (supplier) must submit (no less than 15 business days in advance of a bid date for Public Works projects) a complete description of any changes that will be necessary to the system design, a complete submittal package, a system hydraulic analysis based on the proposed pump (including pipe sizes, flows, velocities, retention times and number and location of recommended valves and cleanouts, if any), a list of exceptions to this specification, and demonstration of compliance to the experience requirements of this specification.

- C. The contractor (supplier) must also complete a Manufacturer Disclosure Statement that will be provided. This information must be submitted for pre-approval of the alternate equipment being proposed and determination of compliance with these Contract Documents. If the equipment differs materially or differs from the dimensions given on the Drawings, the contractor (supplier) shall submit complete drawings showing elevations, dimensions, or any necessary changes to the Contract Documents for the proposed equipment and its installation. Pre-approval, if granted, will be provided in writing by the City to the contractor (supplier) (at least five business days in advance of the bid date for Public Works projects). If pre-approval is obtained for Alternate Equipment, the contractor (supplier) must make any needed changes in the structures, system design, piping or electrical systems necessary to accommodate the proposed equipment at the expense of the contractor (supplier).
- D. All manufacturers proposing equipment for LPSS projects shall have at least 10 years of experience in the design and manufacture of units of identical size(s) and performance to the specified units. All manufacturers proposing equipment for LPSS projects must also have not less than 500 successful installations of low-pressure sewer systems utilizing grinder pumps of like type to the grinder pumps specified herein. An installation is defined as a minimum of 25 pumps discharging into a common force main which forms a low-pressure sewer system. The contractor (supplier) proposing alternate equipment shall also submit an installation list with contact person(s), phone number(s) and date(s) of at least 10 installations of the type of pump specified herein that have been in operation for at least 10 years
- E. In lieu of the above experience clause, the contractor (supplier) of alternate equipment shall be required to submit a 5-year performance bond for 100 percent of the stipulated cost of the equipment. This performance bond will be used to guarantee the replacement of the equipment if it fails within the bond period.

5.9.3 Factory Test

- A. Each grinder pump shall be submerged and operated for 1.5 minutes (minimum). Included in this procedure will be the testing of all ancillary components such as, the anti-siphon valve, check valve, discharge assembly and each unit's dedicated level controls and motor controls. All factory tests shall incorporate each of the above-listed items. Actual appurtenances and controls which will be installed in the field shall be particular to the tested pump only. A common set of appurtenances and controls for all pumps is not acceptable. Certified test results shall be available upon request showing the operation of each grinder pump at two different points on its curve. Additional validation tests include: integral level control performance, continuity to ground and acoustic tests of the rotating components.
- B. All completed stations shall be factory leak tested to assure the integrity of all joints, seams and penetrations. All necessary penetrations such as inlets, discharge fittings and cable connectors shall be included in this test along with their respective sealing means (grommets, gaskets etc.).
- C. The City of Jeffersonville reserves the right to inspect such testing procedures at the grinder pump station manufacturer's facility.

5.9.4 Warranty - Warranty certification shall be completed by the grinder station unit manufacturer. The grinder pump manufacturer shall provide a parts and labor warranty to the property owner on the complete station and accessories, including, but not limited to, panel and redundant check valve, for a period of twenty-four (24) months after property owner's acceptance, but no greater than twenty-seven (27) months after delivery of the complete station and accessories to the property owner. Any manufacturing defects found during the warranty period shall be reported to the manufacturer by the property owner and shall be corrected by the manufacturer at no cost to the property owner.

5.9.5 Grinder Pump

- A. Each grinder pump shall produce 15 U.S. GPM at 0 feet TDH, 11 U.S. GPM at 92 feet TDH, and 7.8 U.S. GPM at 185 feet TDH. The pump must also be capable of operating at negative total dynamic head without overloading the motor. Under no conditions shall in-line piping or valving be allowed to create a false apparent head.
- B. The pump shall be a custom designed, integral, vertical rotor, motor driven, solids handling pump of the progressing cavity type with a single mechanical seal. Double radial O-ring seals are required at all casting joints to minimize corrosion and create a protective barrier. All pump castings shall be cast iron, fully epoxy coated to 8 – 10 mil nominal dry thickness, wet applied. The rotor shall be through-hardened, highly polished, precipitation hardened stainless steel. Plating on the rotor is not acceptable. The stator shall be of a specifically compounded ethylene propylene synthetic elastomer. This material shall be suitable for domestic wastewater service. Its physical properties shall include high tear and abrasion resistance, grease resistance, water and detergent resistance, temperature stability, excellent aging properties, and outstanding wear resistance. Buna-N is not acceptable as a stator material because it does not exhibit the properties as outlined above and required for wastewater service
- C. The grinder pump shall be free from electrical and fire hazards as required in a residential environment. As evidence of compliance with this requirement, the completely assembled and wired grinder pump station in its tank shall be listed by Underwriters Laboratories, Inc., to be safe and appropriate for the intended use. UL listing of components of the station or third-party testing to UL standard shall not be accepted.
- D. The grinder pump shall meet accepted standards for plumbing equipment for use in or near residences, shall be free from noise, odor, or health hazards, and shall have been tested by an independent laboratory to certify its capability to perform as specified in either individual or low-pressure sewer system applications. As evidence of compliance with this requirement, the grinder pump shall bear the seal of NSF International. Third-party testing to NSF standard is not acceptable.

5.9.6 Grinder

- A. The grinder shall be placed immediately below the pumping elements and shall be direct-driven by a single, one-piece motor shaft. The grinder impeller (cutter wheel) assembly shall be securely fastened to the pump motor shaft by means of a threaded connection

attaching the grinder impeller to the motor shaft. Attachment by means of pins or keys will not be acceptable. The grinder impeller shall be a one-piece, 4140 cutter wheel of the rotating type with inductively hardened cutter teeth. The cutter teeth shall be inductively hardened to Rockwell 50 – 60c for abrasion resistance. The shredder ring shall be of the stationary type and the material shall be white cast iron. The teeth shall be ground into the material to achieve effective grinding. The shredder ring shall have a staggered tooth pattern with only one edge engaged at a time, maximizing the cutting torque.

- B. The grinder assembly shall be dynamically balanced and operate without objectionable noise or vibration over the entire range of recommended operating pressures. The grinder shall be constructed so as to minimize clogging and jamming under all normal operating conditions including starting. Sufficient vortex action shall be created to scour the tank free of deposits or sludge banks which would impair the operation of the pump. These requirements shall be accomplished by the following, in conjunction with the pump:
 - a. The grinder shall be positioned in such a way that solids are fed in an upward flow direction.
 - b. The maximum flow rate through the cutting mechanism must not exceed 4 feet per second to minimize jamming.
 - c. The inlet shroud shall have a diameter of no less than 5 inches to prevent exceedance of the maximum flow rate through the cutting mechanism.
 - d. The impeller mechanism must rotate at a nominal speed of no greater than 1,800 rpm.
- C. The grinder shall be capable of grinding all materials found in normal domestic sewage, including, but not limited to, plastics, rubber, sanitary napkins, and disposable diapers into a finely ground slurry that shall pass freely through the passages of the pumps and the 1¼” diameter discharge piping.

5.9.7 Motor

- A. As a maximum, the motor shall be rated 1 HP, 120/240 volts, 1 phase, 60 hertz, 1,725 R.P.M. The motor shall be a capacitor start, ball bearing, air-cooled induction type with Class F insulation, low starting current not to exceed 30 amperes and high starting torque of 8.4 foot pounds. The motor shall be press-fit into the casting for better heat transfer and longer winding life. Inherent protection against running overloads or locked rotor conditions for the pump motor shall be provided by the use of an automatic-reset, integral thermal overload protector incorporated into the motor. The motor protector shall be specifically investigated and listed by Underwriters Laboratories Inc. for the application. Non-capacitor start motors or permanent split capacitor motors will not be accepted because of their reduced starting torque and consequent diminished grinding capability.
- B. The wet portion of the motor armature must be 300 Series stainless steel. To reduce

the potential of environmental concerns, the expense of handling and disposing of oil, and the associated maintenance costs, oil-filled motors will not be accepted. Pump operation during instances of potentially damaging high current or low voltage conditions shall be inhibited by an in-pump electrical monitoring system that has been investigated and listed by Underwriters Laboratories Inc. for the application. Motor start shall be controlled by a DC driven electromechanical relay integrated within the control compartment of the pump. Electrical monitoring shall ensure the relay operates reliably. AC Mechanical contactors for motor start are susceptible to damage from short cycling and will not be accepted.

- C. The pump/core shall be provided with a mechanical shaft seal to prevent leakage between the motor and pump. The seal shall have a stationary silicon carbide seat and silicon carbide rotating surface with faces precision lapped and held in position by a stainless-steel spring.

5.9.8 Electrical Power/Control Cord

- A. Electric power/control cord shall be SOW/SOW-A water resistant 600 V, 60 degrees C, U.L. and C.S.A approved. The single cord shall incorporate both power and sensor leads and shall be a minimum of seven (7) conductors.
- B. The motor cord-entry sealing assembly shall consist of the following components to ensure a positive, redundantly water tight seal:
 - a. Each individual lead shall be interrupted by a solid, uninsulated butt connector to prevent wicking of moisture through the conductor strands. The leads shall then be isolated by a nylon separator to prevent arcing and surrounded with a dielectric epoxy barrier for absolute liquid stoppage.
 - b. The cord moisture seal shall consist of a PVC jacket molded to the outside diameter of the cord which encapsulates the cord outside diameter and the outside diameter of the motor connection leads.
 - c. Sealing of the inside diameter of the motor housing entrance shall be accomplished by the mating of a chamfered pilot on the molded cord jacket with a taper machined in the entrance and secured by a threaded cord grip.
 - d. The sealing components shall be mechanically isolated from any strains by a two-piece cord grip which shall securely grip the molded cord jacket above the moisture-sealing components and bear any mechanical forces applied to the cord. Additionally, the cord grip shall provide redundant sealing of the molded cord jacket outside diameter.
- C. The tank accessway shall include a single NEMA 6P Electrical Quick Disconnect (EQD) for all power and control functions, factory installed with accessway penetrations warranted by the manufacturer to be watertight. The EQD will be supplied with 32', 25' of useable Electrical Supply Cable (ESC) outside the station, to connect to the alarm panel. The ESC shall be installed in the basin by the manufacturer. Field assembly of the ESC into the basin is not acceptable because of

potential workmanship issues. The EQD shall require no tools for connecting, seal against water before the electrical connection is made, and include radial seals to assure a watertight seal regardless of tightening torque. Plug-type connections of the power cable onto the pump housing will not be acceptable due to the potential for leaks and electrical shorts. A junction box shall not be permitted in the accessway due to the large number of potential leak points. The EQD shall be so designed to be conducive to field wiring as required.

5.9.9 Tank and Integral Accessway

- A. The tank shall be a Wetwell/Drywell design made of high-density polyethylene, with a grade selected to provide the necessary environmental stress cracking resistance. Corrugated sections are to be made of a double wall construction with the internal wall being generally smooth to promote scouring. The corrugations of the outside wall are to be a minimum amplitude of 1-1/2" to provide necessary transverse stiffness. Any incidental sections of a single wall construction are to be 0.250" thick (minimum). All seams created during tank construction are to be thermally welded and factory tested for leak tightness. The tank wall and bottom must withstand the pressure exerted by saturated soil loading at maximum burial depth. All station components must function normally when exposed to 150 percent of the maximum external soil and hydrostatic pressure. The tank base shall be designed in a manner that does not require a concrete anti-flotation collar.
- B. Backfill the tank to just below the final surface using Class I or Class II backfill material as defined in ASTM 2321. Flowable fill may also be used.
- C. The minimum total tank storage capacity shall be 70 gallons for a simplex pump station. Larger tanks are an option to increase storage time during a power outage. Duplex pumping systems are also an option for higher flow properties. The tank capacities shall be as shown on the contract drawings.
- D. The tank shall be furnished with one EPDM grommet fitting to accept a 4.50" OD DWV or Schedule 40 pipe.
- E. The Drywell accessway shall be an integral extension of the Wetwell assembly and shall include a lockable cover assembly providing low profile mounting and watertight capability. The accessway design and construction shall enable field adjustment of the station height in increments of 3" or less without the use of any adhesives or sealants requiring cure time before installation can be completed.
- F. The station shall have all necessary penetrations factory sealed and tested. No field penetrations shall be acceptable.
- G. The accessway shall include an integral 2-inch vent to prevent sewage gases from accumulating in the tank.

5.9.10 Station Piping and Valves

- A. All discharge piping shall be constructed of 304 stainless steel. The discharge shall terminate outside the accessway bulkhead with a stainless steel, 1-1/4" Female NPT fitting. The discharge piping shall include a stainless-steel ball valve rated for 235 psi WOG; PVC ball valves or brass ball/gate will not be accepted. The bulkhead penetration shall be factory installed and warranted by the manufacturer to be watertight.
- B. The pump discharge shall be equipped with a factory installed, gravity operated, flapper-type integral check valve built into the stainless-steel discharge piping. The check valve will provide a full-ported passageway when open, and shall introduce a friction loss of less than 6 inches of water at maximum rated flow. Moving parts will be made of a 300 Series stainless steel and fabric reinforced synthetic elastomer to ensure corrosion resistance, dimensional stability, and fatigue strength. A nonmetallic hinge shall be an integral part of the flapper assembly providing a maximum degree of freedom to assure seating even at a very low back-pressure. The valve body shall be an injection molded part made of an engineered thermoplastic resin. The valve shall be rated for continuous operating pressure of 235 psi. Ball-type check valves are unacceptable due to their limited sealing capacity in slurry applications.
- C. The pump discharge shall be equipped with a factory-installed, gravity-operated, flapper-type integral anti-siphon valve built into the stainless-steel discharge piping. Moving parts will be made of 300 Series stainless steel and fabric-reinforced synthetic elastomer to ensure corrosion resistance, dimensional stability, and fatigue strength. A nonmetallic hinge shall be an integral part of the flapper assembly, providing a maximum degree of freedom to ensure proper operation even at a very low pressure. The valve body shall be injection-molded from an engineered thermoplastic resin. Holes or ports in the discharge piping are not acceptable anti-siphon devices due to their tendency to clog from the solids in the slurry being pumped. The anti-siphon port diameter shall be no less than 60% of the inside diameter of the pump discharge piping.

5.9.11 Controls

- A. All necessary motor starting controls shall be located in the core unit secured by stainless steel fasteners. Locating the motor starting controls in a separate enclosure is not acceptable. The wastewater level sensing controls shall be housed in a separate enclosure from motor starting controls.
- B. The level sensor housing must be sealed via a radial type seal; solvents or glues are not acceptable. The level sensing control housing must be integrally attached to pump assembly so that it may be removed from the station with the pump and in such a way as to minimize the potential for the accumulation of grease and debris accumulation, etc. The level sensing housing must be a high-impact copolymer. The use of PVC for the level sensing housing is not acceptable.
- C. Non-fouling wastewater level controls for controlling pump operation shall be accomplished by monitoring the pressure changes in an integral air column connected

to a pressure switch. The air column shall be molded from a copolymer suitable for use in wastewater and with excellent impact resistance. The air column shall have only a single connection between the water level being monitored and the pressure switch. Any connections are to be sealed radially with redundant O-rings. The level detection device shall have no moving parts in direct contact with the wastewater and shall be integral to the pump core assembly in a single, readily exchanged unit. Depressing the push to run button must operate the pump even with the level sensor housing removed from the pump.

- D. All fasteners throughout the assembly shall be 300 Series stainless steel. High-level sensing will be accomplished in the manner detailed above by a separate air column sensor and pressure switch of the same type. Closure of the high-level sensing device will energize an alarm circuit as well as a redundant pump-on circuit. For increased reliability, pump ON/OFF and high-level alarm functions shall not be controlled by the same switch. Float switches of any kind, including float trees, will not be accepted due to the periodic need to maintain (rinsing, cleaning) such devices and their tendency to malfunction because of incorrect wiring, tangling, grease buildup, and mechanical cord fatigue.
- E. To ensure reliable operation of the pressure switches, each core shall be equipped with a factory installed equalizer diaphragm that compensates for any atmospheric pressure or temperature changes. Tube or piping runs outside of the station tank or into tank-mounted junction boxes providing pressure switch equalization will not be permitted due to their susceptibility to condensation, kinking, pinching, and insect infestation. The grinder pump will be furnished with a 6 conductor 14-gauge, type SJOW cable, pre-wired and watertight to meet UL requirements with a FACTORY INSTALLED NEMA 6P EQD half attached to it

5.9.12 Alarm Panel

- A. Each grinder pump station shall include a NEMA 4X, UL-listed alarm panel suitable for wall or pole mounting. The NEMA 4X enclosure shall be manufactured of thermoplastic polyester to ensure corrosion resistance. The enclosure shall include a hinged, lockable cover with padlock, preventing access to electrical components, and creating a secured safety front to allow access only to authorized personnel. The enclosure shall not exceed 10.5" W x 14" H x 7" D, or 12.5" W x 16" H x 7.5" D if certain options are included.
- B. The alarm panel shall contain one 15-amp, double-pole circuit breaker for the pump core's power circuit and one 15-amp single-pole circuit breaker for the alarm circuit. The panel shall contain a push-to-run feature, an internal run indicator, and a complete alarm circuit. All circuit boards in the alarm panel are to be protected with a conformal coating on both sides and the AC power circuit shall include an auto resetting fuse.
- C. The alarm panel shall include the following features: external audible and visual alarm; push-to-run switch; push-to-silence switch; redundant pump start; and high-level alarm capability. The alarm sequence is to be as follows when the pump and alarm breakers are on:

- a. When liquid level in the sewage wet well rises above the alarm level, audible and visual alarms are activated, the contacts on the alarm pressure switch activate, and the redundant pump starting system is energized.
 - b. The audible alarm may be silenced by means of the externally mounted, push-to-silence button.
 - c. Visual alarm remains illuminated until the sewage level in the wet well drops below the “off” setting of the alarm pressure switch.
- D. The visual alarm lamp shall be inside a red, oblong lens at least 3.75” L x 2.38” W x 1.5” H. Visual alarm shall be mounted atop the enclosure in such a manner as to maintain the NEMA 4X rating. The audible alarm shall be externally mounted on the bottom of the enclosure, capable of 93 dB @ 2 feet. The audible alarm shall be capable of being deactivated by depressing a push-type switch that is encapsulated in a weatherproof silicone boot and mounted on the bottom of the enclosure (push-to-silence button).
- E. The entire Alarm Panel shall be listed by Underwriters Laboratories, Inc. or approved equal.
- F. The alarm panel shall include a 20-amp, 250 VAC generator receptacle with a spring-loaded, gasketed cover suitably mounted to provide access for connection of an external generator while maintaining a NEMA 4X rating. An automatic transfer switch shall be provided, which automatically switches from AC power to generator power. Power shall be provided to the alarm panel through the generator receptacle whenever power is present at the receptacle, allowing the audible and visual alarms to function normally in generator mode. When power is no longer applied to the generator receptacle, the panel shall be automatically switched back to the AC Mains power.

5.10 PROPERTY SERVICE CONNECTIONS

5.10.1 General

- A. The property service connection (PSC) is the section of pipe between the R/W or easement line and the mainline sewer. The standard connection for single-family residences will be 1-1/4-inch HDPE; commercial or industrial connections shall be individually considered with the minimum size being 1-1/4-inch HDPE.
- B. All PSC shall be installed with tracer wire as specified for the main line sewer, whether the PSC is installed via HDD or open-cut. Install green metallic “locater” tape labeled “SEWER” above the PSC at a depth of not more than 30 inches when installation is via open-cut.
- C. The location of the PSC shall be approved by the Jeffersonville Wastewater inspector.
- D. The depth of the property service connection at the R/W line shall be at least 3’ deep.
- E. The house connection line shall not be laid parallel to or within three feet of any bearing

wall.

5.10.2 Uni-Lateral Valve Assembly

- A. Each PSC shall require a redundant stainless-steel curb stop/check valve assembly along the 1-1/4-inch service lateral between the grinder pump station and the LPSS main or gravity sanitary sewer main. This assembly is to be located at or near the right-of-way line where it meets the property line of the property owner. The curb stop shall be pressure-tight in both directions. The ball valve actuator shall include position stop features at the fully opened and closed positions. The curb stop/check valve assembly shall be designed to withstand a working pressure of 235 psi.
- B. The stainless-steel check valve shall be integral with the curb stop valve. The check valve will provide a full-ported 1-1/4" passageway and shall introduce minimal friction loss at maximum rated flow. The flapper hinge design shall provide a maximum degree of freedom and ensure seating at low back pressure.
- C. The stainless steel, combination curb stop/check valve assembly shall be provided by the grinder station manufacturer that the LPSS design is based around. The same manufacturer shall warrant the assembly to be free from defects in materials and factory workmanship for two (2) years from date of installation, or twenty-seven (27) months from date of shipment. Each individual assembly shall be hydrostatically tested to 150 psi in the factory.
- D. All pipe connections shall be made using compression fitting connections including a Buna-N O-ring for sealing to the outside diameter of the pipe. A split-collet locking device shall be integrated into all pipe connection fittings to securely restrain the pipe from hydraulic pressure and external loading caused by shifting and settling.
- E. Curb boxes shall be constructed of ABS, conforming to ASTM-D 1788. Lid top casting shall be cast iron, conforming to ASTM A-48 Class 25, providing magnetic detectability, and be painted black. All components shall be inherently corrosion-resistant to ensure durability in the ground. Curb boxes shall provide height adjustment downward (shorter) from their nominal height.

5.11 LPSS MAIN LINE AIR VALVES

- 5.11.1 Recommendations for air valve type, location, and model shall be provided by the LPSS designer in coordination with the grinder pump station and air valve suppliers. Air valves for LPSS shall be suitable for use in small diameter pressure sewer applications. The manufacturer shall be the same as referenced in the Jeffersonville Wastewater Department Construction Standards for Sanitary Sewer Lift Stations / Force Mains or a pre-approved equal if more suitable for LPSS application.

5.12 FLUSHING ASSEMBLY AND VAULT

- 5.12.1 A rectangular valve vault shall be installed on the end of the low-pressure sewer main for ease of accessibility and maintenance of the flushing assembly. It shall be designed so that no part

of a valve or pipe fitting flange is closer than twelve (12) inches to a wall, floor or ceiling to allow easy maintenance access.

- 5.12.2 The valve vault shall be a rectangular pre-cast or cast-in-place concrete structure sized as shown on the plans (4' x 4' minimum). The flushing assembly shall be at least three (3) feet below finished grade of the area. The valve vault base shall be placed on at least six (6) inches of leveled and compacted INDOT No. 8 crushed limestone. The valve vault shall not be placed on unstable (uncompacted) fill due to over-excavation of the lift station area. All exit piping through the wall of the valve vault shall be through cast-in-place openings provided with a resilient seal, Kor-n-seal or equal.
- 5.12.3 The valve vault shall be coated on the outside with an approved bituminous seal coating.
- 5.12.4 Install a standard "City of Jeffersonville" bolt down manhole lid for vault access.
- 5.12.5 The flushing assembly shall be as shown on the detail sheet, and supported the full length on concrete block(s) and secured to the valve vault with stainless steel straps.

5.13 HORIZONTAL DIRECTIONAL DRILLING (HDD)

5.13.1 General

- A. Trenchless installation of LPSS using Horizontal Directional Drilling (HDD) is the preferred method to limit surface disruption. When open-cut installation of LPSS pipe is utilized for main line piping, PSC, HDD pits, or any other excavation, the requirements related to pipe bedding and encasement for flexible gravity sewer pipe and trench backfill shall apply.
- B. The contractor will have the option to offer a different method of trenchless pipe installation, subject to approval and acceptance by the City of Jeffersonville Wastewater Department. When an alternate method is proposed by the Contractor they will be responsible for the final design calculations. A plan of operation and list of proposed materials will be submitted for City of Jeffersonville approval. Structural calculations will be required for all components. Items may include: casing and carrier pipe, tunnel liner plates, working pits, sheeting and shoring, electrical facilities, ventilation, and communications. All design calculations and plans must be signed and sealed and submitted by a professional engineer licensed in the State of Indiana. The contractor will also need to coordinate their excavations beforehand with Indiana 811 - Call Before you Dig.

4.13.2 Surface and Subsurface Conditions

- A. The Contractor shall verify the location of all known and unknown utilities and structures by test pitting prior to any boring or drilling. These utilities and structures may include, but are not limited to:
 - a. Underground utilities such as, but not limited to, storm drains; electric cables; water mains; sewer lines and septic systems; gas, telephone, fiber optic and cable television lines; wells; field drain tiles.

- b. Above-ground utilities and other obstructions such as, but not limited to, electric and telephone poles, buildings, trees, and existing road signs.
- B. Contractor is responsible for inspecting the site, for conducting investigations, surveys and tests, including subsurface investigations and tests, that Contractor determines are necessary for the complete execution of all the work.

5.13.3 Equipment - The directional drilling system to be used shall have the following features:

- A. The system shall be remotely steerable and permit electronic monitoring of tunnel depth and location. The system shall be able to control the depth and direction of the pipe and must be accurate to a window of ± 2 inches.
- B. The system shall utilize a fluid-cutting process, using a liquid clay such as bentonite. This clay shall be totally inert and contain no risk to the environment.
- C. The liquid clay shall remain in the tunnel to increase the stability of the tunnel and to provide a lubricant to reduce frictional drag when the pipe is installed.
- D. The spoils shall be recovered by use of a vacuum system mounted on a vehicle for removal of the spoils. Spoils shall not be discharged into sewers or storm drains. Contractor is responsible for disposal of all spoil material.

5.13.4 Experience and Safety

- A. Prior to commencing any work, Contractor shall demonstrate experience and expertise in trenchless excavation methods by providing a list of six (6) references for which similar work has been performed. These references shall include a name and telephone number for contact so the claims may be verified.
- B. Contractor shall also provide documentation showing successful completion of at least 50,000 linear feet of directional drilling or shall obtain the services of an experienced directional drilling subcontractor meeting the experience requirements of this Section to supervise the installation prior to commencing any work. Conventional trenching shall not be considered as applicable experience.
- C. All supervisory personnel shall be adequately trained and shall have at least four (4) years of experience in directional drilling. Prior to commencing any work, Contractor shall also submit the names and resumes of all supervisory field personnel for review.
- D. Mechanical, pneumatic or water-jetting methods shall not be acceptable due to the risk of surface subsidence and damage.
- E. Upon completion of drilling and pipe installation, Contractor shall remove all spoils from all starting and termination pits and shall restore the surface to its original condition.
- F. Where junctions, manholes or grinder pumps are to be installed, adequate protection in the form of steel plates in traffic areas and timber shutters in other areas shall be used until such times as the manhole or grinder pump is installed and the pit is backfilled and

stabilized. Contractor shall be responsible for maintaining these areas.

- G. Because directional drilling may be performed while existing buried electrical cables are energized; the following safety requirements shall be met:
- a. All drilling equipment must have a permanent, inherent alarm system capable of detecting an electrical current. The ground system shall be equipped with an audible alarm to warn the operator when the drill head nears electrified cable within a safe operating distance.
 - b. All crews shall be provided with grounded safety mats, heavy gauge ground cables with connectors, hot boots and gloves.
 - c. All supervisor personnel shall be adequately trained and have direct supervisory experience in directional drilling.

5.13.5 Drilling Procedure

- A. Prior to any alterations to the work site, Contractor shall complete preconstruction audio-video documentation for the entire work area, including HDD entry and exit points. One copy of the recording shall be given to the City's representative and one copy shall remain with Contractor for a period of one year following the completion of the project.
- B. The work site as indicated on the Contract Drawings shall be graded or filled to provide a level working area. No alterations beyond what is required for operations shall be made. Contractor shall confine all activities to the designated work areas and construction limits.
- C. The entire drill path shall be accurately surveyed with entry and exit stakes placed in the appropriate locations within the areas indicated on the Contract Drawings. If Contractor is using a magnetic guidance system, the drill path will be surveyed for any surface geo-magnetic variations or anomalies.
- D. Environmental protection necessary to contain any hydraulic or drilling fluid spills shall be put in place as needed, including berms, liners, turbidity curtains and other erosion control measures. Contractor shall adhere to all applicable environmental regulations. Fuel and oil must not be stored in bulk containers within 200 feet of any water-body or wetland.
- E. Pipe resting on paved or hardened surfaces (i.e., sidewalks, asphalt, concrete, gravel, etc.) shall be placed on pipe rollers before being pulled into the drill hole with rollers spaced close enough to prevent excessive sagging and dragging of the pipe upon rough surfaces which could scar the pipe.
- F. Contractor shall calibrate the directional drilling head locator at the start of the day and at each new directional drilling operation. A daily calibration log shall be kept for review.

- G. The directional drilling operator shall have full control of the direction of the drilling tool at all times. Shallow, misdirected or other unsuccessful drill attempts shall be abandoned and filled at the direction of the City's representative and at no additional cost to the City.
- H. The maximum drill angle shall be fifteen degrees measured perpendicular to grade to the design depth elevation.
- I. A pilot hole shall be drilled on the drill path with no deviations greater than 5% of depth over a length of 100 feet. In the event that the pilot hole does deviate from the drill path more than 5% of depth in 100 feet, Contractor shall notify the City's representative, who may require Contractor to pull back and re-drill from the location along the drill path before the deviation at no additional cost to the City.
- J. In the event of a drilling fluid fracture, inadvertent returns or returns loss occurs during pilot hole drilling operations, Contractor shall cease drilling, wait at least 30 minutes, inject a quantity of drilling fluid with a viscosity exceeding 120 seconds as measured by a Marsh funnel viscometer and then wait another 30 minutes. If mud fracture or returns loss continues, Contractor shall cease operations and notify the City's representative. The City's representative and the Contractor will discuss additional options and work will then proceed accordingly.
- K. Upon successful completion of the pilot hole, Contractor will ream the drill hole to a minimum of 25% greater than the outside diameter of the installed pipe using the appropriate tools. In no case shall the size of the reaming operations result in a hole size greater than 150% of the outside diameter of the installed pipe. Contractor will not attempt to ream at one time more than the drilling equipment and mud system are designed to safely handle.
- L. After successfully reaming the drill hole to the required diameter, Contractor shall pull the pipe through the drill hole. In front of the pipe will be a swiveling mandrel. Once pull-back operations have commenced, operations must continue without interruption until the pipe is completely pulled into the drill hole. During pull-back operations Contractor shall not apply more than the maximum safe pipe pull pressure at any time.
- M. Two strands of tracer wire shall be pulled back with the pipe. The wires shall be installed along the pipe, fastened securely to the pipe at five (5) foot intervals, and terminating above ground with the lead taped around each structure. The wire shall be brought up to the ground level every four hundred (400) feet through a vinyl coated aluminum riser pipe with cap and/or at all line valve boxes. The wires shall be connected using DBR Direct Burial Splice Kit manufactured by 3M Electrical Products Division, Austin, TX or approved equal. The riser pipe and cap shall not be placed in areas subject to vehicular traffic. The tracer wire shall be capable of, and demonstrated to have, continuous transmission of tracing signal along the full length of the installed pipe.
- N. In the event the pipe becomes stuck during pull-back, Contractor shall cease pulling operations to allow any potential hydro-lock to subside prior to re-commencing pulling operations. If the pipe remains stuck, Contractor shall notify the City's

representative. Contractor shall discuss options with the City's representative and then work will proceed accordingly.

- O. At all drill pits and directional drilling entrances and exits to the surface, a backhoe or equivalent shall be used to gradually return the bore depth to the prescribed depth. All drill pits and directional drilling entrances and exits to the surface shall be backfilled and compacted as specified elsewhere in these Standards, depending on the final surface restoration.
- P. Test/pressure relief holes (potholes) may be dug at the Contractor's discretion along the bore route to confirm alignment and grade, and to relieve subsurface pressure. The Contractor is fully responsible for ensuring installation along the correct alignment and grade and to comply with all other drilling operation logging and installation verification requirements.
- Q. Contractor shall provide completed forms or computer-generated output to the City's representative on a daily basis for checking line and grade of the drilling operation.

5.13.6 Testing and Inspection

- A. After the pipe has been installed, allow pipe manufacturer's recommended amount of time, but not less than four (4) hours, for cooling and relaxation due to tensile stressing prior to hydrostatic testing.
- B. The pipe is to be hydrostatically tested for leaks after complete installation of the entire LPSS. To identify any defects during installation, the pipe shall be hydrostatically tested after joining into continuous pullback sections following installation. Hydrostatic testing shall be in accordance with Section 8.4.
- C. A horizontal tolerance of up to three (3) feet left or right of the planned alignment will be permitted at any point on the alignment provided the pipeline is still within the easement or right-of-way where it was planned.
- D. Tolerances for vertical alignment compared to planned alignment will be judged on a case-by-case basis depending on the location relative to surrounding utilities, creation of new high or low points, required relocation of air/vacuum valves, and the effect on the pumping system curves.
- E. Sections of pipe that do not meet the requirements shall be replaced by Contractor at no additional cost to the City. The rejected pipe shall be grouted and abandoned in place or removed and all voids filled as directed by the City's representative, at no additional cost to the City.

6.0 Fats, Oil & Grease (FOG) Requirements

Introduction

Fats, oils, and greases (FOG) are a significant concern for the City of Jeffersonville collection system and the wastewater treatment plant. When not disposed of properly, FOG components congeal and accumulate along the walls of sanitary sewers. This constricts the pipes, impedes the flow of wastewater, and raises the potential for blockage. Grease also affects the proper operation of pump stations, leading to sewage accumulation in wet wells. Either of these situations can eventually result in a sanitary sewer overflow in which wastewater is discharged from a manhole, or wastewater enters homes and businesses. This is both an environmental issue and a public health concern, in which sewage can contaminate the ground, local bodies of water, and any property which the wastewater comes into contact. These overflows are strictly prohibited by the State and Federal regulations.

The financial consequences related to excessive FOG is potentially two-fold. Maintenance crews of the Department devote considerable time to cleaning sewerage components, and treatment processes may be hindered at the City of Jeffersonville's wastewater treatment plant.

FOG discharges relate directly to the preparation, cooking, and disposal of food items. These can originate from commercial, institutional, and industrial facilities. However, it is restaurants and related commercial food service users that are the most significant source of FOG due to the amount of oil and grease used in cooking, and with other food preparation.

The purpose of this standard is to set forth requirements for non-residential users of the City's sanitary/combined sewer system to capture and dispose of FOG, enabling the City to comply with all applicable federal and state laws, and to prohibit the discharge of any wastewater containing more than 100 part per million of FOG.

To reduce the operational and maintenance costs of the City by limiting the introduction of FOG in the sewer system, to reduce the impact of the City's wastewater treatment plant operations by limiting the amount of FOG delivered by the City's sewer system and to protect the general public health and prevent environmental disturbances by eliminating or reducing sanitary sewer overflows due to grease accumulations.

Applicability of this Provision

The provisions of this standard are applicable to all commercial users as well as all other businesses or dischargers whose discharges contain fats, oil and or greases in concentrations above one hundred milligrams per liter (100 mg/l), including all commercial food users, institutions with food service, and industries with food service that discharge to the City's wastewater collection system.

6.1 General Requirements

Discharges of wastewater containing more than 100 parts per million of FOG, measured as Hexane Extractable Material (HEM), are prohibited.

All commercial food service users, and institutions or industries with food service, shall install, operate, and maintain at their expense a grease control device.

The maintenance costs related to excessive grease in the City's sewer system, and traceable to the food service operations of a facility, shall be the responsibility of the user.

The maintenance costs of sewer overflow that is related to excessive grease in the City's sewer system, and traceable to the food service operations of a facility, shall be the responsibility of the facility causing the problem.

Any fines imposed upon the City by the State of Indiana or the United States of America in regard to a sewer overflow which is related to excessive grease in the City's sewer system, and traceable to the food service operations of a facility, shall be the responsibility of the user.

New Sewer System Users

All new commercial food service users, and institutions or industries with food service, shall be required to install the appropriate grease control device, approved by the Department, prior to initiating operations. Following a review of preliminary construction plans, the Department shall notify the owner in writing of the specific grease control device for installation. In general, this will be a grease interceptor for all sizable restaurants, and for hospitals, schools, motels, and industries.

The Department strongly recommends that each new building, located in a commercial complex generally referred to as a strip mall, provide a stub-out for a separate waste line for possible future grease interceptor installation. This shall apply to all buildings in the complex not initially planned as restaurants. The designer of such new structures shall consider suitable physical space and sewer gradient on the property that will be conducive for the installation of a grease interceptor(s).

Existing User; New User in Existing Building

All existing commercial food service users, and institutions or industries with food service, shall have grease control devices that meet the same general requirements for installation and design for new users. This shall also pertain to a new user that begins operations in an existing building, and an existing user that expands its food service operations.

Any commercial food service user, or institution or industry with food service, whose grease handling facilities or methods are determined by the Department to be inadequate to prevent excessive FOG from entering the City's sewer system, shall be notified of the deficiencies, the required improvements, and a compliance deadline. Required improvements may include modifications of the maintenance schedule, the installation of a larger, or additional, grease trap, or the installation of a grease interceptor. The user may be required to provide a schedule of corrective action to meet full compliance.

A facility without a grease control device shall be allowed a compliance deadline not to exceed two (2) months for the installation of a grease trap, or not to exceed six (6) months for the installation of a grease interceptor, following written notification from the Department. If a facility, which is required to install a grease interceptor, does not have an existing grease trap, than the latter shall be installed within two (2) months of notification by the Department, unless the grease interceptor is installed within that time period.

The Utility Director or his/her designee may decide certain instances that the installation of a grease interceptor on an existing facility property is physically impossible due to space limitations, is not possible due to inadequate slope for proper gravity flow, or for other reasons. The facility manager shall be responsible for an aggressive kitchen Best Management Practices program to produce wastewater that meets the FOG requirements.

Grandfathering of Existing Users

Existing facilities in which a grease trap or interceptor has been installed prior to the effective date of these Standards shall be allowed to continue the operation of the existing unit only if the device meets the FOG discharge limits.

An existing user which operates a grease trap may be required to add a sample valve to the discharge line from the device and prior to a union with any sewer line in the building. This requirement shall typically be limited to facilities in which there is a history of poor grease trap maintenance.

An existing user which expands its food service operations may be required to install a larger grease trap, an additional grease traps, or a grease interceptor to replace, or operate in conjunction with, an existing grease trap.

6.2 Design, Sizing and Installation Requirements

All grease traps and interceptors shall be designed, sized and installed according to the standards of the Uniform Plumbing code, and the Department's *Sanitary Sewer Standards* and be of a type, capacity, and location approved by the Utility Director or his/her designee.

Various formulas exist to calculate the proper size of a grease interceptor. The Department shall not require the use of any one formula, but rather sound engineering judgment in this instance. The Utility Director or his/her designee shall make all final decisions on the requirement for a specific grease control device, its design, and its size.

General Specifications

1. Grease Traps

- a. A grease trap shall be constructed of corrosion-resistant metal or plastic;
- b. be accessible for cleaning, maintenance, and inspection; contain properly installed and functioning baffles necessary to achieve the appropriate retention time to allow for proper separation of FOG and solids from the remaining water; handle the flow from no more than three (3) kitchen sinks, and shall be located inside the facility as close to the sink(s) as possible;
- c. never receive wastewater from sanitary sewer; not receive discharge that exceeds 120 degrees Fahrenheit;
- d. not receive discharge from a dishwasher or food grinding unit;
- e. be installed with an approved flow control or restricting device to restrict the flow to the rated capacity of the trap, and for cleaning purposes; and
- f. be installed with a sample valve on the discharge line from the device and prior to the union with any sewer line in the building.
- g. The minimum size requirement for an "under the sink" grease trap is the equivalent of a 25-gallon per minute/50-pound capacity trap. Grease traps shall have flow control restrictor and a vent pipe. No dishwasher (gray water), or sanitary wastewater (black water) line shall be allowed to be connected to an "under the sink" or floor grease trap.

2. Grease Interceptors

- a. A grease interceptor shall be constructed of precast concrete with a minimum compressive strength of 3,000 psi. Any alternative shall be approved by the Department prior to installation
- b. be sized from a minimum of 1,000 gallons to a maximum of 3,000 gallons;
- c. contain multiple chambers and properly positioned tee piping to achieve a thirty (30) minute retention time before wastewater is discharged to the City's sewer system;
- d. be installed on the facility, with access for inspection, cleaning, pumping, and maintenance;
- e. not be installed in areas subject to heavy traffic, where possible,
- f. shall be accessible for all inspections at all times, having no permanent or temporary structure or container placed directly over the unit; have a minimum 24" diameter manhole, extended to finish grade, over each chamber, interior baffle wall, and sanitary tee;
- g. Have solid manhole covers that are traffic rated and that prevent infiltration of storm water or other surface water. Any gaskets shall be positioned beneath the cover; be designed with a minimum 8" diameter sample box or sample tee at the outlet; receive the discharge from all facility drains and fixtures through which grease may be released including all sinks, floor drains, food grinding units, and dishwashers;

- h. never receive wastewater from sanitary sewer lines; be installed at a minimum distance of ten (10), and a maximum distance of fifty (50) feet from dishwashers and sinks to allow for optimal cooling of the wastewater; not receive discharge that exceeds 120 degrees Fahrenheit;
- i. include properly sized solids interceptor, and have its volume increased by 25 %, when receiving discharge from a food grinding unit; and
- j. be installed with an approved flow control or restricting device to stop the flow for cleaning purposes.

3. Minimum Requirements

- a. Minimum acceptable size of Grease Control Equipment for each Food Service Establishment Classification will be as follows:
 - i. Deli, Ice Cream shops, Beverage Bars, Coffee Shops, Mobile Food Vendors- 25 gallons per minute/50-pound GT if an exemption has not been granted by the City of Jeffersonville.
 - ii. Limited-Service Restaurants / Caterers – 1,000 gallon or equivalent device which has been approved by the City of Jeffersonville
 - iii. Full Service Restaurants- 1,000-gallon GI or equivalent device which has been approved by the City of Jeffersonville
 - iv. Buffet and Cafeteria Facilities- 1,500-gallon GI or equivalent device which has been approved by the City of Jeffersonville
 - v. Institutions (Schools, Hospitals, Prisons, etc)- 2,000-gallon GI or two 1000 gallon GI installed in series or equivalent devices which has been approved by the City of Jeffersonville
- b. The City of Jeffersonville will review Grease Control Equipment sizing information received from the Food Service Establishment’s engineer, architect or contractor. City of Jeffersonville will make a decision to approve, or require additional Grease Control Equipment volume, based on the type of Food Service Establishment, the number of fixture units, and additional calculations. Grease interceptor capacity should not exceed 2,000 gallons for each interceptor tank. In the event that the grease interceptor calculated capacity needs to exceed 2,000 gallons, the Food Service Establishment shall install an additional interceptor of the appropriate size. If additional interceptors are required, they shall be installed in series unless the manufacturer states the design is intended to be installed in parallel.
- c. Grease interceptors that are installed in series shall be installed in such a manner to ensure positive flow between the tanks at all times. Therefore, tanks shall be installed so that the inlet invert of each successive tank shall be a minimum of 2 inches below the outlet invert of the preceding tank.
- d. Grease interceptors that are installed in series shall include adaptors, gaskets or flexible transition couplings of minimum of schedule 40 PVC pipe.

6.3 General Maintenance

- 1. Proper maintenance of grease traps and interceptors is crucial to establish optimal efficiency of the devices. They shall be cleaned as often as necessary to ensure that:
 - a. Floating material and sediment do not accumulate to impair the operation of the device.
 - b. The discharge of the FOG to the City’s sewer system meets the stated limitations.
 - c. No visible grease is observed in the discharge.
- 2. Upon request, the Department shall provide information that describes proper cleaning and maintenance of the devices. However, due to the varying designs and sizes, the user shall follow specific manufacturer guidelines for cleaning and maintenance, at a minimum, in all instances.

3. General guidelines for cleaning and maintenance include:
 - a. Grease traps and interceptors shall be kept free at all times of such solid materials as gravel, sand, bones, shells, cigarettes, utensils, towels and rags that will reduce the effective volume of the device and increase the frequency of cleaning.
 - b. The total depth of the surface FOG, combined with the settled solids, should not exceed approximately 25 % of the total depth of the liquid/solid column.
 - c. Based upon the above, a grease trap will typically require cleaning every 1-4 weeks, a grease interceptor will generally require cleaning every 2-4 months. However, the actual loading on a device will determine the specific cleaning schedule.

Kitchen Best Management Practices: The application of kitchen Best Management Practices (BMPs) serves as a critical initial step in reducing the amount of oil and grease that enters a facility's grease control device, and therefore in prolonging the periods between cleaning and maintenance. All facilities with food service operations shall establish kitchen BMPs, and provide continuous training and monitoring of employees.

Waste Grease Disposal

All facilities are encouraged to use designated buckets for the disposal of waste grease removed from grease traps during cleaning. Such material shall not be combined with cooking oil that is to be recycled. Buckets should have a well-sealing lid and shall be disposed at a disposal site permitted to receive such waste.

Grease Interceptor Cleaning and Maintenance

Specific Requirements for the servicing of grease interceptors shall be include the following:

1. Cleaning and related maintenance shall be performed at least every four (4) months, unless written permission for a schedule of less frequent service has been obtained by the City.
2. Cleaning and maintenance shall include the evacuation of all contents of the interceptor, including floating materials, wastewater, and settled solids.
3. All waste removed from an interceptor shall be disposed at a disposal site permitted to receive such wastes.
4. Clean water shall be returned to the interceptor following evacuation and cleaning.
5. Other than the clean water immediately returned to the interceptor to complete maintenance, none of the waste material removed from an interceptor shall be discharged to the City's sewer system.

Prohibitions

The following practices and devices are prohibited

1. Any modification of a grease interceptor, such as alteration or removal of flow constricting device, that causes flow to rise above the design capacity of the unit or reduce the retention time.
2. Interceptor cleaning that involves only skimming the surface layer, partial cleaning, or use any method that does not remove the entire contents of the vessel.
3. The introduction of such agents as concentrated detergents, other surfactants, emulsifiers, degreasers, solvents, or any other type of product that will liquefy grease wastes.
4. The addition of any chemical enzyme product unless written permission has been granted by the City.
5. The addition of bacteria unless written permission has been granted by the City.
6. The use of automatic, or mechanically operated, grease removal systems, unless written permission has been granted by the City.

Recordkeeping

Facilities with a grease control device shall maintain records of all cleaning and maintenance of the device. These records shall include, at a minimum:

1. The date and time of service.
2. The name and signature of user representative who performed or witnessed the service (if applicable).
3. The contract company that performed the service (if applicable).
4. The name and signature of the contract company employee (if applicable).
5. The gallons of waste removed.
6. A copy of the service record or manifest from the contract company (if applicable).

All facilities shall keep records of their waste grease disposal or recycling, including the number and size of containers, the dates on which they were disposed of or recycled, and the name and contact information of the disposal or recycling service location.

Records shall be placed in a logbook, folder, or binder, shall be maintained for at least three (3) years, and shall be immediately made available to the Department on demand during an inspection, or at intervals specified.

Right of Entry and Inspections

Authorized representatives of the City shall have the right to enter the premises of any facility operating a grease control device to determine whether the user is in compliance with all requirements of this standard. Entry shall be during normal business hours and for the purpose of inspection and evaluation of the facility's grease control program. If entry is refused, the Department shall have recourse to the remedies provided by law for entry.

Inspection may involve any or all of the following items:

1. the integrity of the grease control device,
2. the amount of grease present in the device,
3. wastewater appearance and clarity,
4. cleaning and maintenance records,
5. waste grease disposal and recycling storage and records,
6. all food processing areas and fixtures, and,
7. sampling of discharge water from device.

It shall be the responsibility of the user to keep its grease control device accessible at all times. The Department shall have the option of requesting that a grease trap be opened by a representative of the user.

The result of the inspection shall be made available to the user's representative verbally. A written report shall be mailed within ten (10) days of the inspection if the facility is found to be out of compliance with any of the requirements outlined in these standards, and shall include the necessary corrective action and a timetable for accomplishing such improvements.

6.4 Sampling & Testing

Sampling and Testing

The Department may collect and analyze annual samples for laboratory testing to determine if a user is in compliance with this standard. The expense of any additional sample collection, shipment, and analyses shall be borne by the user.

Frequency of Sampling

Sampling shall be at least annually from any facility maintaining a grease trap/interceptor. The laboratory analysis shall consist of FOG, BOD and suspended solids testing. Additional sample collection and testing shall be done at the discretion of the Department, and relate to a history of the user's discharge, or to existing conditions.

Sampling Methods and Cost

Sampling shall involve grab samples which are collected, stored transported, and analyzed in accordance with the procedures specified in 40 CFR Part 136. All annual testing required by the Department shall be conducted by the Department's wastewater laboratory at the Department's expense. Any additional sampling and testing required by the Department to demonstrate compliance for facilities that have experienced noncomplying discharges, shall be conducted by a private commercial laboratory which is in good standing with the Indiana Department of Environmental Management and shall be at the user's expense.

Sample Collection

Sample collection from a grease interceptor shall be from the sample box at the outlet of the device, if present, or from the nearest manhole. Sample collection from a grease trap shall be from the sample valve at the outlet of the device, if present, or from the nearest manhole.

Analysis Reports

A copy of the analysis report of any laboratory testing on samples collected from a facility by anyone other than the Department shall be provided to the Department. The Department shall mail a copy to the user within ten (10) business days of receipt by the Department. The report shall include, at a minimum, an explanatory cover letter, the chain of custody form, the laboratory at which testing took place, the results of the testing, the test methods used, and the dates of analyses.



WASTEWATER DEPARTMENT CAPACITY FEES

Residential Homes (single family) Capacity Fee: \$4,900*

* *Please contact the Wastewater Department Office at 812-285-6451 fees for new projects not on the following list or for industrial dischargers.*

ADOPTED: MARCH 5, 2026

Commercial, Non-industrial Capacity Fees

The following information is for reference only. Actual calculations for commercial sewer tap construction permits will be determined after a footprint detailing the usage of the commercial space is provided to the Wastewater Department Office located at 423 Lewman Way at River Ridge.

The charge for non-residential, non-industrial connections shall be computed by establishing the total gallonage flow rate per day for the connection by dividing the total by 310 G.P.D and multiplying the quotient by the amount of the residential sewer connection. Gpd/sf shall mean gallons per day per square foot as noted below.

<i>TYPE OF FACILITY</i>	<i>FLOW</i>
Airports	
• Per employee	20 gpd
Institutions-Nursing Homes, Hospitals, etc. (per bed)	200 gpd
Schools (without gym and showers) per student	15 gpd
Schools (with gym and shower) per student	25 gpd
Camps	
• Per Toilet	400 gpd
• Showers	300 gpd
• Washing Facilities	5 gpd
Mobile Home Parks (per space)	200 gpd
Motels and Hotels (per room)	100 gpd
Restaurants, Cafeterias, etc. (per square foot)	0.35 gpd
Bars, Cocktail Lounges	0.35 gpd
Manufacturing	
0 - 4,999 square feet	0.20 gpd/sf
Add to Base 5,000 square feet	
• 5,000 - 24,999 square feet	0.50 gpd/sf
• 25,000 - 99,999 square feet	0.015 gpd/sf
• 100,000 - 499,999 square feet	0.0125 gpd/sf
• 500,000 - 999,999 square feet	0.0100 gpd/sf
Doctor's Office	
• Doctors/Nurses	75 gpd
• Support Staff	20 gpd
Warehousing	

0 - 4,999 square feet	0.100 gpd/sf
Add to Base 5,000 square feet	
• 5,000 - 9,999 square feet	0.050 gpd/sf
• 10,000-24,999 square feet	0.015 gpd/sf
• 25,000-99,999 square feet	0.0125 gpd/sf
• 100,000 -499,999 square feet	0.010 gpd/sf
• 500,000 – 999,999 square feet	0.0005 gpd/sf
Offices	
0 - 4,999 square feet	0.30 gpd/sf
<i>Add to Base 5,000 square feet</i>	
• 5,000 – 9,999 square feet	0.25 gpd/sf
• 10,000 and over	0.20 gpd/sf
Banks and Financial Institutions	0.30 gpd/sf
Theaters, Drive-ins (per parking ramp)	7 gpd
Theaters, indoor (per seat)	4 gpd
Service Stations (without car wash)	0.25 gpd/sf
Service Station (with car wash)	
(all improvements except washing bay) .25 GSFPD plus	650 gpd/bay
Service Stations, Garages, Mechanics, Repair Establishments	0.25 gpd/sf
Duplexes, Condos, Townhouses and Apartments with washer hookups	
• 1 bedroom	200 gpd
• 2 bedroom	260 gpd
• 3 bedroom	310 gpd
Duplexes, Condos, Townhouses and Apartments without washer hookups	
• 1 bedroom	120 gpd
• 2 bedroom	150 gpd
• 3 bedroom	300 gpd
Churches (with kitchen) (per sanctuary seat or equivalency in case of benches)	5 gpd
Laundry (per washing machine)	110 gpd
Grocery Stores with grinder facilities	0.35 gpd/sf
Grocery Stores	0.20 gpd/sf
Retail Establishments	0.10 gpd/sf
Kennels and Vet Clinics	
• Cages per cage	5 gpd
• Inside runs per run	10 gpd
• Outside runs per run	20 gpd
• Surgery plus per room	50 gpd
• Staff	
• Doctor	75 gpd
• Staff	20 gpd
Picnic Areas or Parks	
• per toilet	400 gpd
• showers	300 gpd
• washing facilities	5 gpd
Club Houses, Community Houses, etc.	0.35 gpd/sf
Not-for-profit, subject to attorney's opinion	0.20 gpd/sf
Health clubs, and beauty and barber shops, etc.	0.30 gpd/sf
Self-service car wash	650 gpd/bay
Day care center	0.25 gpd/sf
Dental Offices	
• Chair(s)	200 gpd
• Employees	75 gpd



Sewer Manhole Test Report

Date: _____

Sheet: 1 of 2

Project/Subdivision Name:	Contractor:
Testing Conducted by: <i>(Company Name & Signature)</i>	Department Inspector: <i>(Name & Signature)</i>

Testing procedure shall be as specified in ASTM C 1244 (latest revision) – Standard Test Method For Concrete Sewer Manholes by Negative Air Pressure (Vacuum) Test, further as modified by the allowable vacuum loss shall not exceed 1" Hg (mercury) within the minimum times as contained in the following Table.

Manhole Depth (ft)	Manhole Diameter		
	48-in	60-in	72-in
	<i>Minimum Test Time, seconds</i>		
8	20	26	33
10	25	33	41
12	30	39	49
14	35	46	57
16	40	52	67
18	45	59	73
20	50	65	81
22	55	72	89
24	59	78	97
26	64	85	105
28	69	91	113
30	74	98	121

No.	Manhole		Time Req'd	Time		Vacuum,(Inch Hg)			Pass/ Fail
	Diameter, in	Depth, ft		Start	End	Start	End	Loss	

POLICY AND REQUIREMENTS FOR DIRECTIONAL DRILLING (BORING) BY CONTRACTORS AROUND EXISTING SEWERS AND FORCE MAINS

The following are the requirements for Directional Drilling by companies installing pipes or cables for the installation of new facilities within the City of Jeffersonville sewer service area.

1. If a new Utility line will be crossing the City of Jeffersonville’s gravity sewers or force main by directional drilling (boring), the company boring must verify the location of the sewer line by potholing (vacuum excavating) prior to the installation of the utility line. The pothole must expose the gravity sewer or force main’s depth. If no sewer line is exposed, the pothole shall be a minimum of (2) feet below the desired depth of the proposed utility line. The gravity lines are within (6) feet either side of the marked location and (10) feet either side for force mains.

2. The location of the proposed boring shall be marked consistent with the Indiana 811 requirements. It is also recommended that prior to boring, the utility company obtain a sewer map from the GIS Administrator in the Wastewater Department for the approximate location of the gravity sewer or force mains.

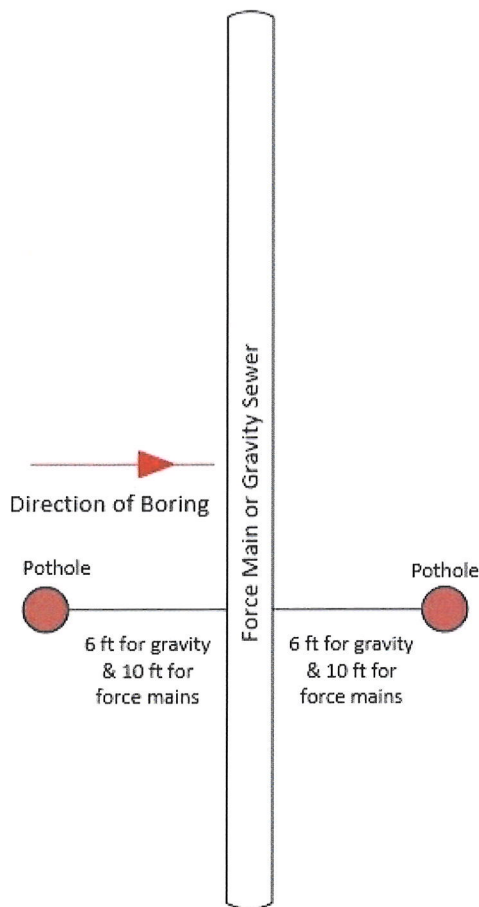

For HDD (Boring)
perpendicular to the
sewer/force main

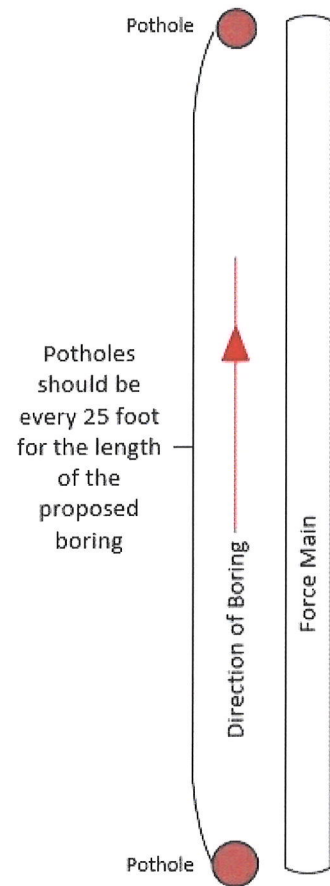

For HDD (Boring)
parallel to the force
main

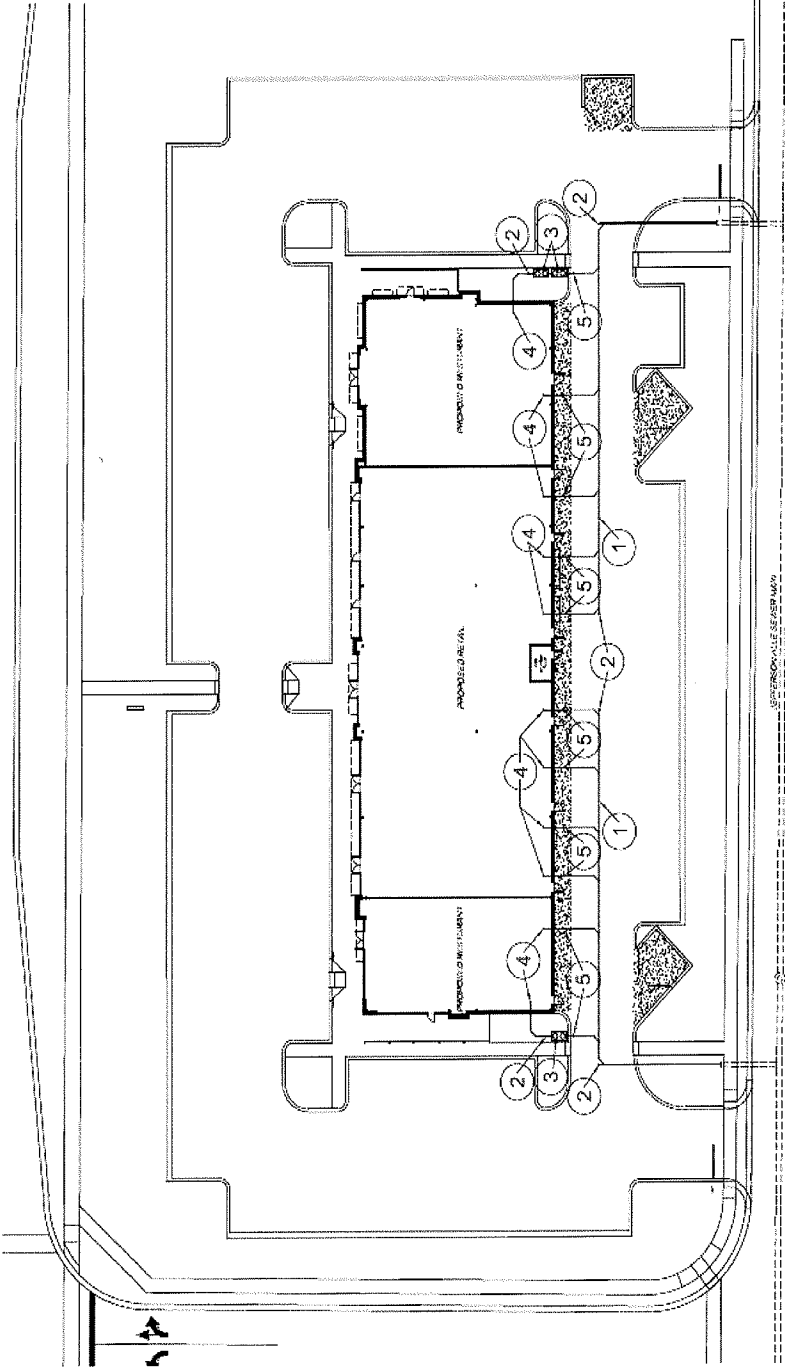

CONSTRUCTION NOTES - UTILITY

- ① 6" SDR-35 PVC LATERAL
- ② CLEAN OUT
- ③ GREASE INTERCEPTOR
- ④ CLEAN OUT
- ⑤ 6" CLEAN CHECK BACKFLOW PREVENTION VALVE BY RECTOSEAL.

STANDARD SANITARY SEWER DRAWINGS & DETAILS FOR

CITY OF JEFFERSONVILLE, INDIANA



SHEET INDEX	
SHEET NO.	TITLE
1	COVER SHEET
2	PIPE BEDDING & CROSSING DETAILS
3	SANITARY SEWER STRUCTURE DETAILS
4	SANITARY LATERAL CONNECTION & MISC. DETAILS
5	FORCE MAIN DETAILS
6	ELECTRICAL CONTROL CABINET AND ENCLOSURE DETAILS
7	PUMP STATION DETAILS
8	LOW PRESSURE SEWER SYSTEM DETAILS

NOTE:
REFER TO THE CONSTRUCTION STANDARDS FOR
ADDITIONAL SPECIFICATIONS AND DETAILS.

SANITARY SEWER STANDARD DETAILS
CITY OF JEFFERSONVILLE
JEFFERSONVILLE, INDIANA



Revisions	Vertical Scale:	NOTED
1. 2025 Update of Standard Drawings & Details	Horizontal Scale:	NOTED
	Date:	1/30/2025

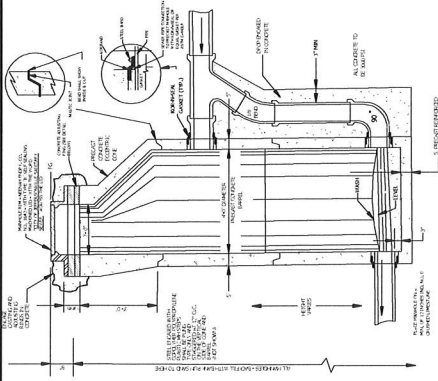

CITY OF JEFFERSONVILLE, INDIANA
TYPE "E" SANITARY SEWER DROP MANHOLE
 NO SCALE

NOTE: CONTRACTOR SHALL BE RESPONSIBLE FOR VERIFYING ALL PIPE ELEVATIONS TO THE FINISHED GROUNDWATER SURFACE. ALL MANHOLE STRUCTURES SHALL BE CONSTRUCTED TO THE FINISHED SURFACE. FINISH GRADE SHALL BE ADJUSTED TO MATCH THE FINISHED GROUND SURFACE.

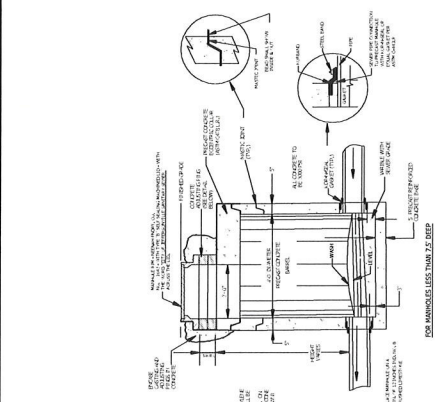

CITY OF JEFFERSONVILLE, INDIANA
TYPE "C" SANITARY SEWER MANHOLE
 NO SCALE

NOTE: CONTRACTOR SHALL BE RESPONSIBLE FOR VERIFYING ALL PIPE ELEVATIONS TO THE FINISHED GROUNDWATER SURFACE. ALL MANHOLE STRUCTURES SHALL BE CONSTRUCTED TO THE FINISHED SURFACE. FINISH GRADE SHALL BE ADJUSTED TO MATCH THE FINISHED GROUND SURFACE.

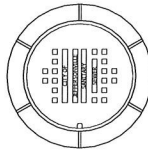

CITY OF JEFFERSONVILLE, INDIANA
MANHOLE FRAME WITH SOLID LID DETAIL
 NO SCALE

NOTE: MANHOLE FRAMES, SOLID LID SHALL BE BLACK WITH THE WORD "CITY OF JEFFERSONVILLE SANITARY SEWER" ACROSS THE LID.

NOTE: REFER TO THE CONSTRUCTION STANDARDS FOR ADDITIONAL SPECIFICATIONS AND DETAILS.

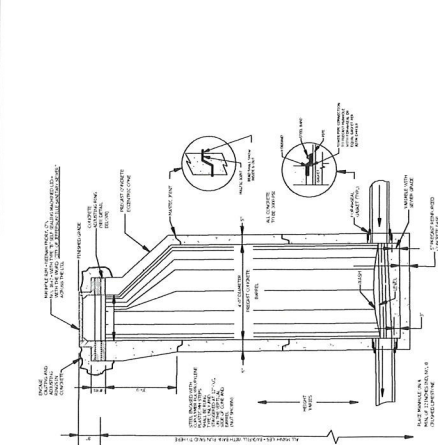

CITY OF JEFFERSONVILLE, INDIANA
TYPE "B" SANITARY SEWER MANHOLE
 NO SCALE

NOTE: CONTRACTOR SHALL BE RESPONSIBLE FOR VERIFYING ALL PIPE ELEVATIONS TO THE FINISHED GROUNDWATER SURFACE. ALL MANHOLE STRUCTURES SHALL BE CONSTRUCTED TO THE FINISHED SURFACE. FINISH GRADE SHALL BE ADJUSTED TO MATCH THE FINISHED GROUND SURFACE.

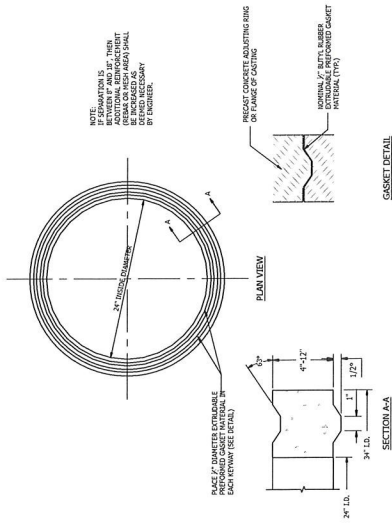

ADJUSTING RING DETAIL
 NO SCALE

NOTE: DIMENSIONS BETWEEN AND BY OTHER MANHOLE STRUCTURES SHALL BE AS SHOWN UNLESS OTHERWISE NOTED. FINISH GRADE SHALL BE ADJUSTED TO MATCH THE FINISHED GROUND SURFACE.

REGULAR CONCRETE ADJUSTING RING OR FRAME OF CASTING

SECTION A-A

3\"/>

24\"/>

NOTE: DIMENSIONS BETWEEN AND BY OTHER MANHOLE STRUCTURES SHALL BE AS SHOWN UNLESS OTHERWISE NOTED. FINISH GRADE SHALL BE ADJUSTED TO MATCH THE FINISHED GROUND SURFACE.

REGULAR CONCRETE ADJUSTING RING OR FRAME OF CASTING

SECTION A-A

3\"/>

24\"/>

24\"/>

3\"/>

DATE	1/20/2025
REVISION	1. 2025 Update of Standard Details

Vertical Scale: NOTED

Horizontal Scale: NOTED

Date: 1/20/2025

Sheet 3

3 of 8

SANITARY SEWER STANDARD DETAILS
 CITY OF JEFFERSONVILLE
 JEFFERSONVILLE, INDIANA

SANITARY SEWER STRUCTURES DETAILS

Page 84



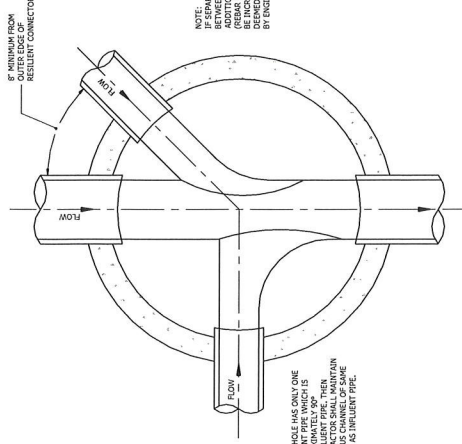

FLOW CHANNEL DETAIL
NO SCALE

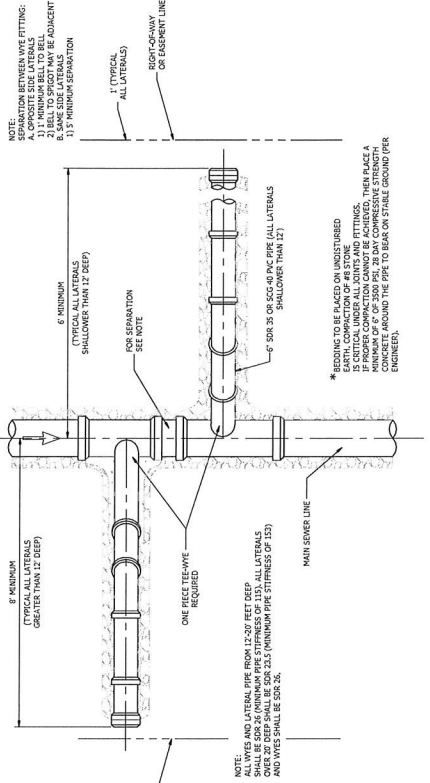

PLAN VIEW

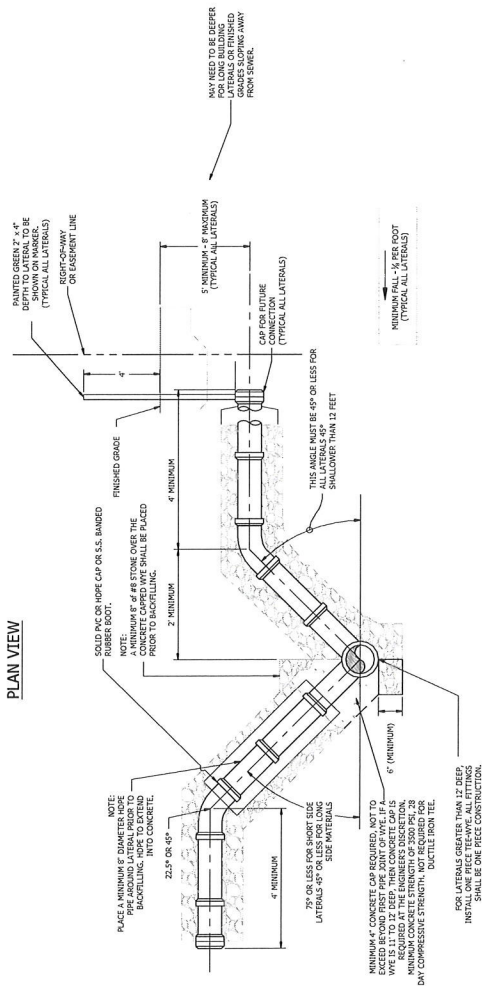

SECTION

LESS THAN 12' DEEP
MORE THAN 12' DEEP

NOTE: ALL FITTINGS SHALL BE 451022 FITTINGS AT 5' BELOW GRADE BE SDR 35 TO 20' DEEP OR SDR 32.2 GREATER THAN 20' DEEP.

NOTE: REFER TO THE CONSTRUCTION STANDARDS FOR ADDITIONAL SPECIFICATIONS AND DETAILS

NOTE: TO BE USED WHEN CLEAR DISTANCE FROM EXTERIOR PIPE DIAMETER TO OTHER LATERALS, FORCE MAINS, ETC. AND ALL OTHER PIPES IS 8\"/>

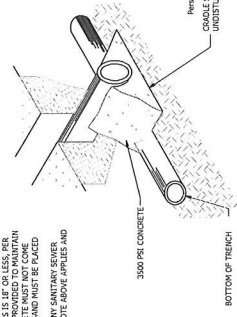

CONCRETE CRADLE DETAIL
NO SCALE

SERVICE LATERAL DETAIL
NO SCALE

**SANITARY SEWER STANDARD DETAILS
CITY OF JEFFERSONVILLE
JEFFERSONVILLE, INDIANA**

SANITARY LATERAL CONNECTION & MISCELLANEOUS DETAILS

DESIGNED BY	1. DESS, URBAN & PARTNER ENGINEERS & ARCHITECTS	VERTICAL SCALE	NOTED
DRAWN BY		HORIZONTAL SCALE	NOTED
CHECKED BY		DATE	1/30/2023



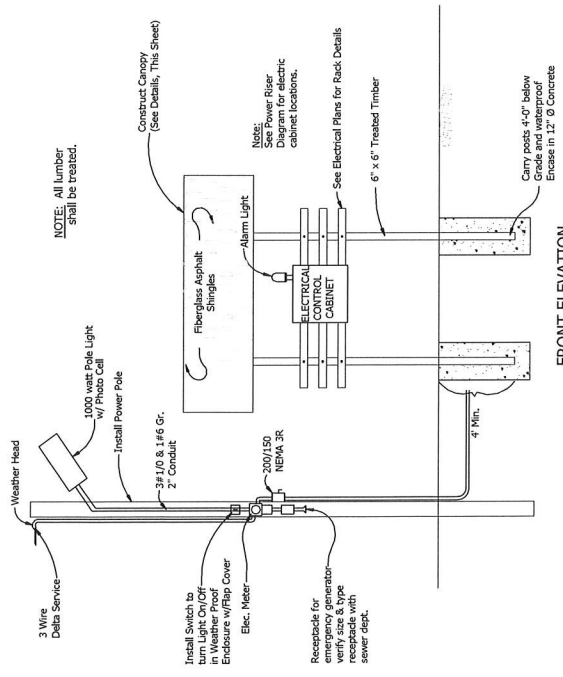

FRONT ELEVATION

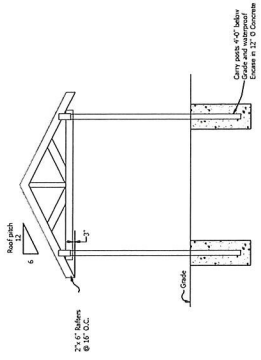

SIDE ELEVATION

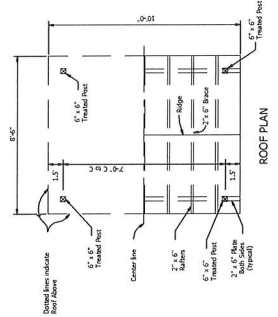

ROOF PLAN

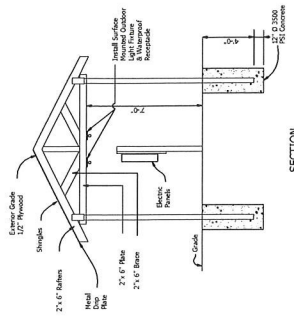

SECTION

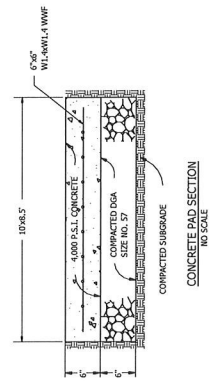

CONCRETE PAD SECTION
1/8\"/>

NOTE: REFER TO THE CONSTRUCTION STANDARDS FOR ADDITIONAL SPECIFICATIONS AND DETAILS

SANITARY SEWER STANDARD DETAILS
CITY OF JEFFERSONVILLE
JEFFERSONVILLE, INDIANA
ELECTRICAL CONTROL CABINET AND ENCLOSURE DETAILS

Revision	NOTED
1.00/02/23	1. 2025 Update of SANITARY SEWER STANDARDS & DETAILS
Vertical Scale:	NOTED
Horizontal Scale:	NOTED
Date:	1/30/2023

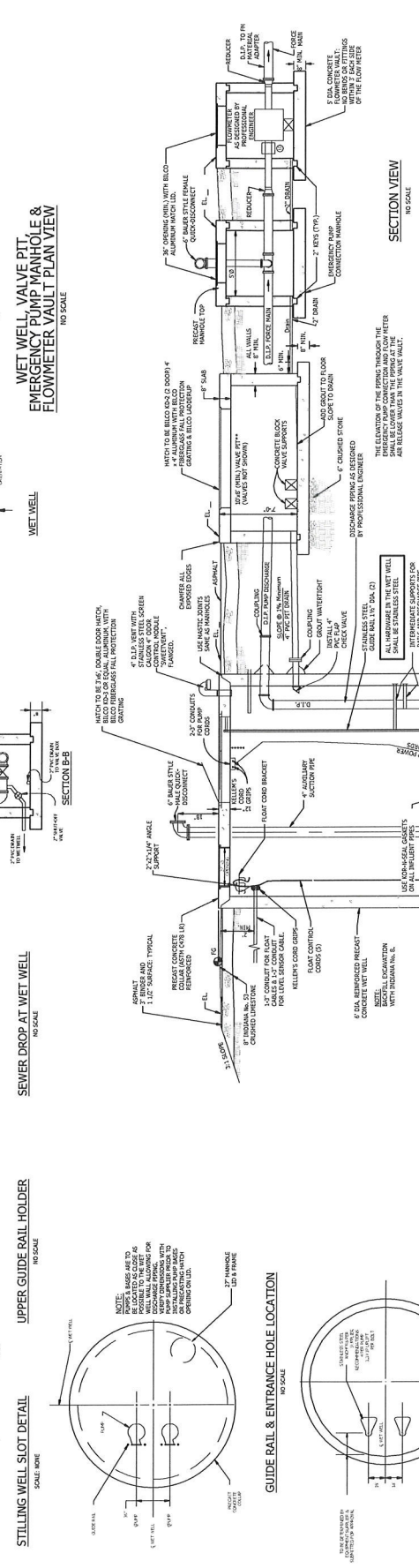
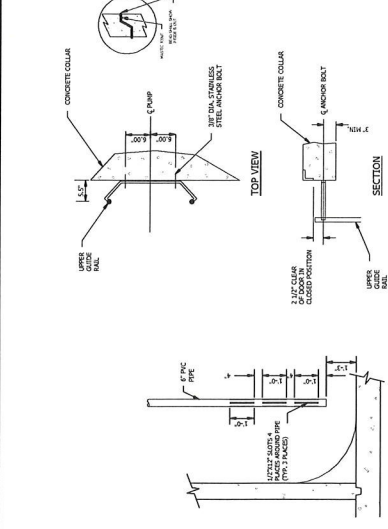
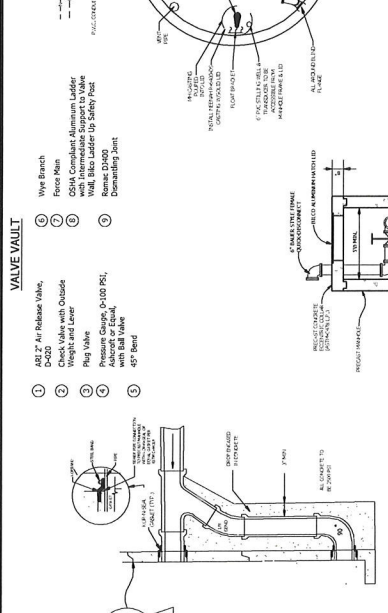
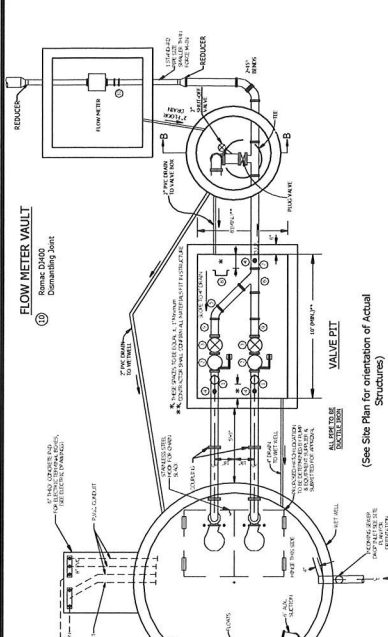

NOTES:
REFER TO THE CONSTRUCTION STANDARDS FOR ADDITIONAL SPECIFICATIONS AND DETAILS

REVISIONS:
1. SEE SHEET OF SEWER COLLARS & CHAINS

VERTICAL SCALE: NOTED
HORIZONTAL SCALE: NOTED
DATE: 1/20/2025

KEY: 7 of 8

INTRODUCING THE NEW PRE-CAST BALLAST METHOD FROM THE PRESSURE SEWER EXPERTS AT COVALENI!!!

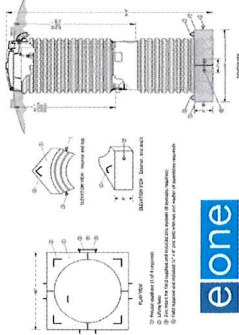

DETAILS PROVIDED BY
EONE SEWER SYSTEMS,
ALL RIGHTS RESERVED.

- 1 Transition Fitting
- 2 Breezer Ball Valve
- 3 2" x 2" Manhole
- 4 90° Elbow, Cast Iron
- 5 Male-Cam Lock Casing and Cap, 2" x 2" Manhole
- 6 Station Stone Wall Strip
- 7 Concrete Support Block
- 8 8" x 8" Concrete Walk with Bolt Down Leg, ISO Traffic Patch
- 9 Cast Iron Spool Piece
- 10 Minimum 6" of Insulated Concrete
- 11 2" x 1/4" Size Reducer

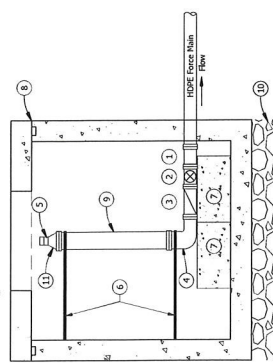

FORCE MAIN FLUSHING ASSEMBLY DETAIL

